

UT320/UT340 Operations Manual and Software Developer's Guide

Revision 1.3

UTEX SCIENTIFIC INSTRUMENTS INC.

2319 Dunwin Drive, Unit 8
Mississauga, Ontario L5L 1A3
Canada

Tel (905) 828-1313

Fax (905) 828-0360

E-mail: tech-support@utex.com

Web Site: www.utex.com

Copyright © 2017 UTEX Scientific Instruments Inc.
All Rights Reserved

CONTENTS

NOTICE 1

UTEX Ultrasonic Pulser Receiver System 2

 How to Reach Us..... 2

 Packing List..... 2

 Optional Accessories..... 2

Before You Begin..... 3

 Warnings 3

 Accidentally Pulsing Into the 50Ω Inputs of Other Instruments..... 3

 Possible Transducer Damage Due to High Pulse Voltages..... 3

 Stop the Pulser Before Connecting and Disconnecting Transducer Cables..... 3

Quick Start Guide 4

 Typical Set-up..... 4

 Pulse Echo Set-up..... 4

 Pitch Catch Set-up..... 4

 Connecting to an Oscilloscope..... 5

Introduction 11

 System Overview 11

 Modes of Operation..... 11

 Stand Alone Operation (UT340 only)..... 11

 Computer-Controlled Operation (UT320 & UT340)..... 11

 Connecting to Your Computer 12

Getting Started..... 13

 Front Panel Controls (UT340 only)..... 13

 Instrument Mode Keys..... 13

 Display Menu Keys 14

 Numeric Input Keys..... 14

 Rotary Knob..... 15

 Power Button and Indicator LED..... 15

Instrument Connectors 15

 Front Panel Connectors 15

Rear Panel Connectors.....	16
Turning the Instrument On and Off.....	17
Using the UT340 Front Panel Power Button.....	17
Using the UT320 Front Panel Power Button.....	17
Using the Rear Panel Power Switch.....	17
Power and Status LED.....	17
Possible Errors.....	18
Windows™ Software Interface Overview.....	18
Controlling the Instrument.....	19
Pulser Mode Settings (UT340 only).....	19
Starting and Stopping the Pulser.....	19
Receiver Mode Settings.....	20
System Settings.....	21
I/O Control Settings.....	22
I/O Setting Configuration.....	23
When the Instrument Intervenes.....	24
Save and Recall Options.....	24
Saving Instrument Settings.....	24
Recalling Instrument Settings.....	24
Function Key Assignments.....	24
Windows™ Software Interface.....	25
UTEXUT Windows™ Software Interface Installation.....	25
Minimum Requirements.....	25
Installation Instructions.....	25
Main Control Panel.....	25
Instrument Power Button.....	26
COM Port.....	26
BAUD Rate.....	26
Help.....	26
Upload Settings.....	27
Address Change.....	27
Log.....	27

About Spinners.....	27
Pulser Controls.....	27
Receiver Controls.....	28
Filter Controls Button (For models with filter option only).....	28
I/O and Relay Setup.....	28
Filter Controls (For models with filter option only).....	29
Phase Control.....	29
I/O and Relay Setup.....	30
I/O Controls.....	30
Relays.....	31
Message Window.....	32
System Messages.....	33
Instrument System Messages.....	33
Specifications.....	34
Pulser.....	34
Wideband Receiver Amplifier.....	35
Continuously Variable Filters.....	36
Instrument Interface.....	36
Command Structure Overview.....	37
Communications Protocol.....	40
Instrument System Power up.....	41
NORMAL POWER UP.....	41
Instrument System Power Down.....	42
INPUTS.....	43
Address (ADR).....	43
Designation (DSG).....	43
Filter High Pass Enable (FHE).....	43
Filter High Pass Frequency (HPF).....	43
Filter Low Pass Enable (FLE).....	43
Filter Low Pass Frequency (LPF).....	44
Filter Output Phase (FIN).....	44
Flow Control (FCE).....	44

I/O Line A Control (IOA)	44
I/O Line A Direction (TAD).....	44
I/O Line A Function (TAF)	45
I/O Line A Name (TAN).....	45
I/O Line A Polarity (TAP).....	45
I/O Line A Tracking (TAT)	45
I/O Line B Control (IOB).....	45
I/O Line B Direction (TBD).....	45
I/O Line B Function (TBF)	45
I/O Line B Name (TBN)	46
I/O Line B Polarity (TBP).....	46
I/O Line B Tracking (TBT).....	46
I/O Line C Control (IOC).....	46
I/O Line C Direction (TCD)	46
I/O Line C Function (TCF)	46
I/O Line C Name (TCN)	46
I/O Line C Polarity (TCP).....	47
I/O Line C Tracking (TCT).....	47
I/O Line D Control (IOD)	47
I/O Line D Direction (TDD)	47
I/O Line D Function (TDF).....	47
I/O Line D Name (TDN)	47
I/O Line D Polarity (TDP)	47
I/O Line D Tracking (TDT)	48
LCD Contrast Control (CON).....	48
Lock (SL)	48
Over Current Reset (OCR)	48
Over Voltage Reset (OVR)	48
Pitch Catch Gain (RPC)	48
Pulse Echo Gain (PEG)	49
Pulse Repetition Frequency (PRF).....	49
Pulse Voltage (PV).....	49

Pulse Width (PW)	49
Pulser Run/Stop (PON).....	50
Read Date and Time (RDT).....	50
Receiver Gain (RG)	50
Receiver to Pitch Catch Mode (RPC)	50
Receiver to Pulse Echo Mode (RPE).....	51
Relay A Control (RLA)	51
Relay A Function (RAF).....	51
Relay A Name (RAN).....	51
Relay A Polarity (RAP)	51
Relay B Control (RLB)	51
Relay B Function (RBF)	51
Relay B Name (RBN).....	52
Relay B Polarity (RBP).....	52
Retransmission Status (SRT)	52
System Power On/OFF (SP).....	52
System Settings (OK).....	52
System Temperature (GST).....	53
Trigger Source (TSI/TSE).....	53
OUTPUTS.....	54
PON	54
PRF	54
PV	54
PW.....	55
RG.....	55
PCG.....	55
PEG.....	55
RPC.....	55
RPE	56
TSE.....	56
TSI.....	56
RESPONSES TO QUERIES FROM THE PC.....	57

System Settings (OK).....	57
ERRORS.....	58
COMMAND NOT SUPPORTED.....	58
DONE/PROGRAM LINE LOW AFTER LCA DATA SENT.....	58
EXTERNAL PRF LIMITED.....	58
FLASH CORRUPTED.....	58
INTERNAL PRF LIMITED.....	58
INVALID INCREMENT, VALUE ROUNDED.....	59
INVALID SUPPLY NUMBER.....	59
MAX POWER LIMIT.....	59
MAX POWER WHILE IDLE.....	59
MAX POWER WHILE STARTING.....	59
MAX POWER, HV ON.....	59
OVER-CURRENT.....	59
OVER-CURRENT WHILE IDLE.....	59
OVER-CURRENT, HV ON.....	60
OVER-VOLTAGE.....	60
OVER-VOLTAGE WHILE IDLE.....	60
OVER-VOLTAGE WHILE RUNNING.....	60
OVER-VOLTAGE WHILE STARTING.....	60
OVER-VOLTAGE, HV ON.....	60
P/C GAIN CORRUPTED, SET TO MIN.....	60
P/E GAIN CORRUPTED, SET TO MIN.....	61
PRF CORRUPTED, SET TO MIN.....	61
PULSE VOLTAGE LIMITED.....	61
PULSE WIDTH LIMITED.....	61
SETTINGS ARE MANUALLY LOCKED.....	61
SYSTEM ERROR.....	61
VALUE OUT OF RANGE.....	61
VOLTAGE CORRUPTED, SET TO MIN.....	61
Rear Panel Connector Pin Assignments.....	62
Control Input/Output.....	62

RS-232	62
RS-485	62
Warranty	63
Product and Warranty Registration.....	64

NOTICE

UTEX Scientific Instruments Inc. reserves the right to revise and improve its products without notice. This document describes the state of this product at the time of publication and may not reflect the product at all times in the future. UTEX Scientific Instruments Inc. assumes no responsibility for any errors or consequential damages that may result from the use of or misinterpretation of any information contained in this document.

This document, or parts thereof, may not be copied, photocopied, reproduced, translated, or reduced to any electronic medium or machine-readable form, for any purpose, without written permission from UTEX Scientific Instruments Inc.

UTEX ULTRASONIC PULSER RECEIVER SYSTEM

Thank you for purchasing this instrument from UTEX. We have worked hard to design and build a product that we hope will meet your needs for many years to come and help make your work more productive.

Should you have any questions about the operation of this instrument, please give us a call so that we can do our best to help you.

HOW TO REACH US

We can be reached by telephone from 8:30 a.m. until 5:00 p.m. E.S.T. or by mail and e-mail at:

UTEX Scientific Instruments Inc.
2319 Dunwin Drive, Unit 8
Mississauga, Ontario
Canada
L5L 1A3

Tel: 905-828-1313 Fax: 905-828-
0360 E-mail: tech-support@utex.com
web site: www.utex.com

PACKING LIST

Included with your pulser receiver in the shipping carton is:

- Power Cord
- Serial Cable
- Software Interface CD(s)
- User Manual

Should any of the above-mentioned items be missing, please let us know immediately.

OPTIONAL ACCESSORIES

A continuously variable filter module is available for both the UT320 and the UT340. This feature gives the instrument second order low-pass and high-pass filtering as well as selectable RF output signal inversion. This module can be ordered separately and installed in existing instruments. Please call for a quote anytime and specify part number 340.1.4.4. when ordering.

A fast-pulse pulser module is available and can be ordered instead of the standard-pulse pulser. This pulser gives the instrument a faster pulse rise time to drive transducers up to 150 MHz. This can be retrofitted into your UT320 and UT340 at any time. Please call for a quote and specify part number 340.1.4.3-001 when ordering.

BEFORE YOU BEGIN

PLEASE READ THIS MANUAL BEFORE ATTEMPTING TO USE YOUR INSTRUMENT.

The POWER available from these pulsers CAN DAMAGE other equipment if improperly connected. Should the instructions provided in this manual not be clear enough, please contact our technical support staff who will be pleased to assist you further.

WARNINGS

ACCIDENTALLY PULSING INTO THE 50Ω INPUTS OF OTHER INSTRUMENTS

The PULSE/REC connector should not be directly connected to sensitive 50Ω inputs as found on oscilloscopes, digitizers and peak detectors unless a limiter is used. The RF OUTPUT connector is intended to be connected to these devices.

POSSIBLE TRANSDUCER DAMAGE DUE TO HIGH PULSE VOLTAGES

The high voltages available from these pulsers (up to 500V) can damage some thinly ground or thinly deposited elements such as those found in zinc oxide transducers. Before using high frequency transducers at high voltages, please check with the transducer manufacturer for suggested maximum voltages.

STOP THE PULSER BEFORE CONNECTING AND DISCONNECTING TRANSDUCER CABLES

Do not disconnect or connect transducers to the PULSE/REC jack while the pulser is enabled.

A feature of the UT300 series of pulser receivers is that they can detect short circuit conditions in transducer cables and turn the pulser off before any damage occurs. This “soft start” process works best when the pulser is enabled using the Run/Stop button. When the pulser is started, each pulser variable is ramped up to its current set point through a series of steps. The operating conditions are checked at every step and uncharacteristically low load impedances will abort the start sequence before high power levels are reached.

QUICK START GUIDE

TYPICAL SET-UP

Integrating your UTEX pulser receiver into an existing system or new system is very easy to do. The pictures on the following pages show how to connect your UT320 or UT340 to both an oscilloscope and digitizer for either pulse echo or pitch catch applications.

An example of a basic ultrasonic system (without motion) involving a UTEX pulser receiver includes an ultrasonic transducer, a digitizer card and a data acquisition and imaging software package such as Inspection Ware.

PULSE ECHO SET-UP

The ultrasonic transducer connects to the PULSE/REC connector on the pulser receiver. The RF OUT on the pulser receiver connects to the CHA input on the digitizer card. The EXT/TRIG on the pulser receiver connects to the TRIG output on the digitizer card.

The pulser receiver should be set up to use an external trigger source and the receive mode should be set to Pulse/Echo. The amplifier on the digitizer card should be set to +12dB and the trigger source for the card should be set to internal. Any further amplification should come from the pulser receiver.

NOTE: DO NOT connect the PULSE/REC directly to the digitizer card. This could destroy the input circuitry of the card.

PITCH CATCH SET-UP

The transmitting ultrasonic transducer connects to the PULSE/REC connector on the pulser receiver.

The receiving ultrasonic transducer connects to the RECEIVE connector on the pulser receiver. The RF OUT on the pulser receiver connects to the CHA input on the digitizer card. The EXT/TRIG on the pulser receiver connects to the TRIG output on the digitizer card.

The pulser receiver should be set up to use an external trigger source and the receive mode should be set to Pitch/Catch. The amplifier on the digitizer card should be set to +12dB and the trigger source should be set to internal. Any further amplification should come from the pulser receiver. Enable the pulser on the instrument.

NOTE: DO NOT connect the PULSE/REC directly to the digitizer card. This could destroy the input circuitry of the card.

CONNECTING TO AN OSCILLOSCOPE

The pulser receiver can also be connected to an oscilloscope. In this case, the ultrasonic transducer connects to the PULSE/REC connector on the instrument. The RF OUT on the instrument connects to the CH1 input on the oscilloscope. The input impedance of the oscilloscope must be set to 50 Ω . The SYNC OUT of the pulser receiver connects to the CH2 input on the oscilloscope.

The pulser receiver should be set up to use an internal trigger source and the receive mode should be set to Pulse/Echo. The oscilloscope should be set to trigger on the rising edge of CH2. Enable the pulser on the instrument.

The RF signal received can be amplified using the gain controls on the instrument. The pulse shape can be fine tuned using the voltage and width controls.

NOTE: DO NOT connect the PULSE/REC directly to the oscilloscope. This could destroy the input circuitry of the oscilloscope.

UT320 - Oscilloscope connections for: Pulse Echo Mode

Before proceeding, read "Warnings" section in the Users Manual

Always stop the pulser before connecting or disconnecting transducer cables

Never connect the pulser output (PULSE/REC) directly to the input of other instruments

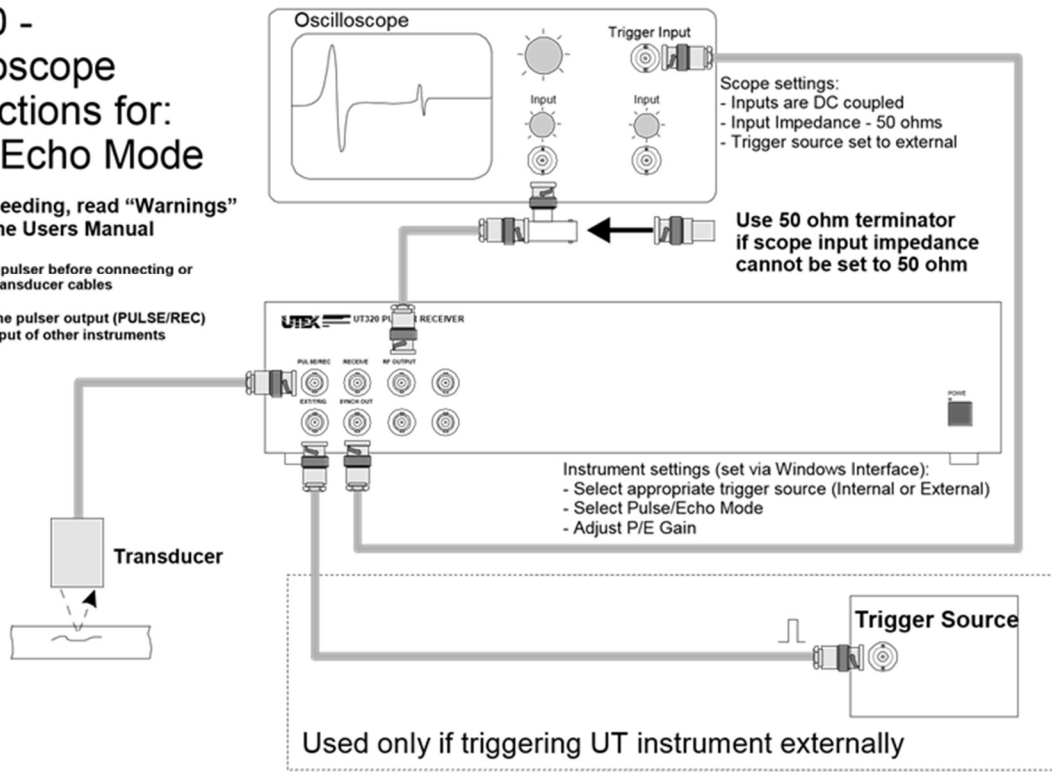

UT320 - Digitizer Card connections for: Pulse Echo Mode

Before proceeding, read "Warnings" section in the Users Manual

Always stop the pulser before connecting or disconnecting transducer cables

Never connect the pulser output (PULSE/REC) directly to the input of other instruments

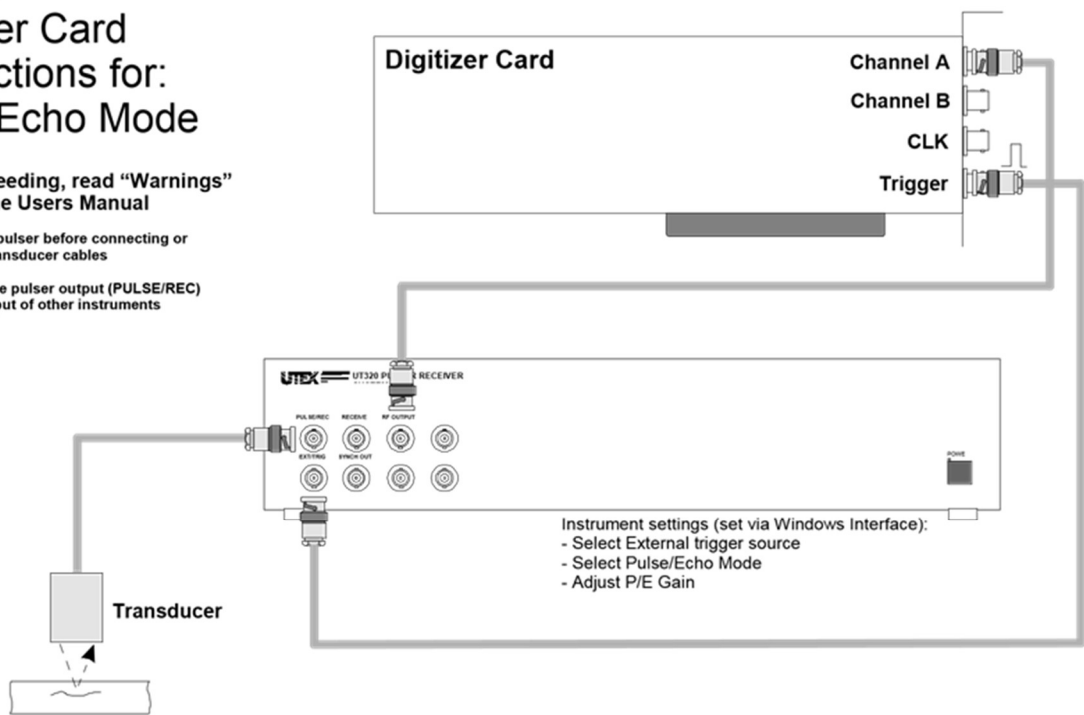

UT320 - Oscilloscope connections for: Pitch Catch Mode

Before proceeding, read "Warnings" section in the Users Manual

Always stop the pulser before connecting or disconnecting transducer cables

Never connect the pulser output (PULSE/REC) directly to the input of other instruments

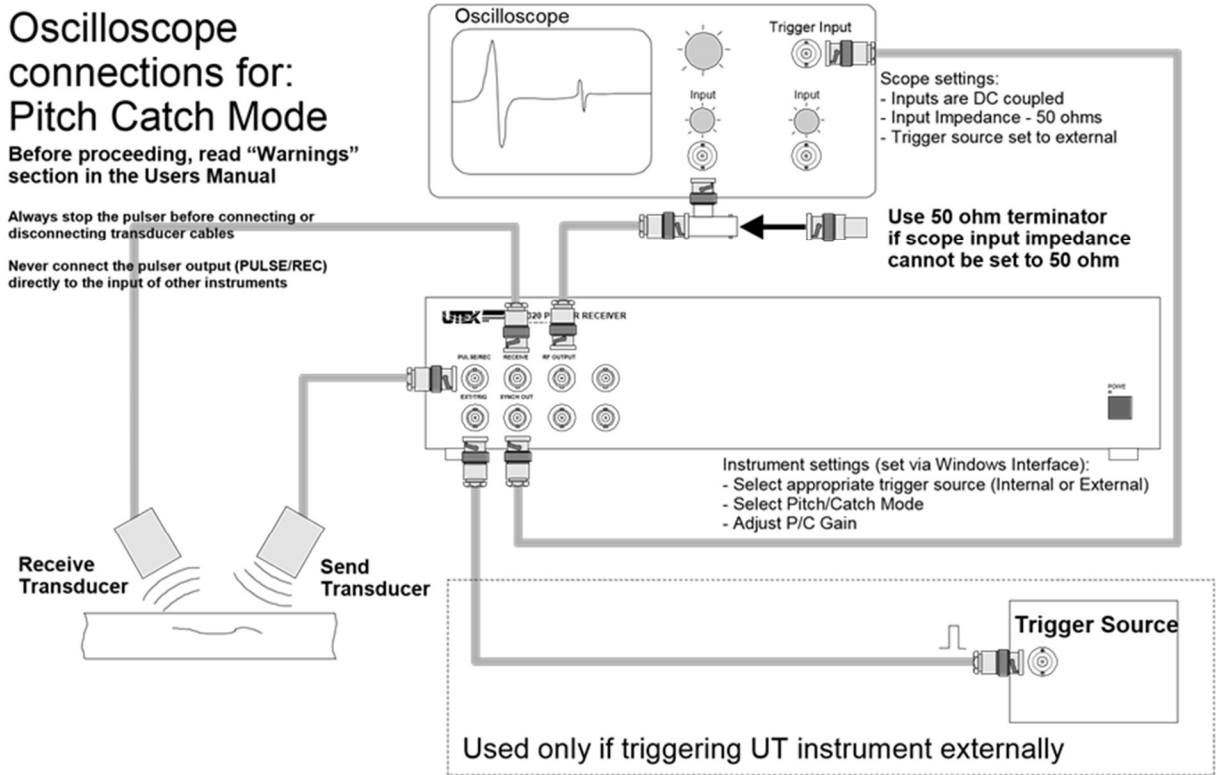

UT320 - Digitizer Card connections for: Pitch Catch Mode

Before proceeding, read "Warnings" section in the Users Manual

Always stop the pulser before connecting or disconnecting transducer cables

Never connect the pulser output (PULSE/REC) directly to the input of other instruments

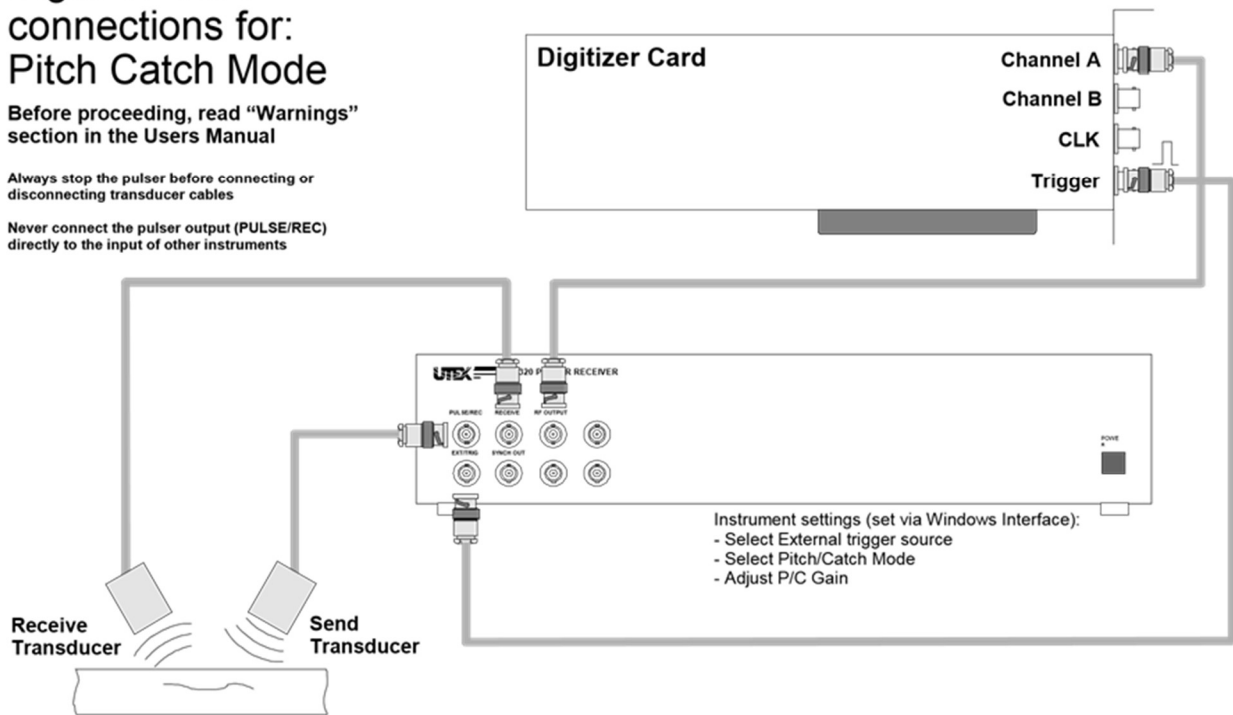

UT340 - Oscilloscope connections for: Pulse Echo Mode

Before proceeding, read "Warnings" section in the Users Manual

Always stop the pulser before connecting or disconnecting transducer cables

Never connect the pulser output (PULSE/REC) directly to the input of other instruments

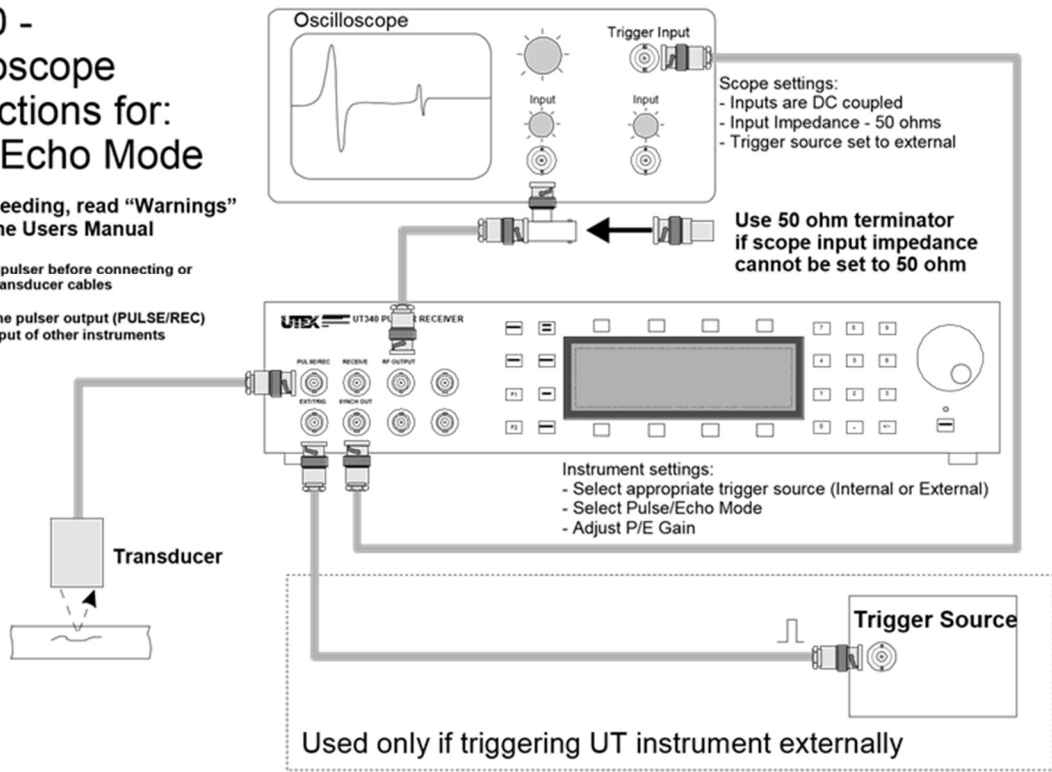

UT340 - Digitizer Card connections for: Pulse Echo Mode

Before proceeding, read "Warnings" section in the Users Manual

Always stop the pulser before connecting or disconnecting transducer cables

Never connect the pulser output (PULSE/REC) directly to the input of other instruments

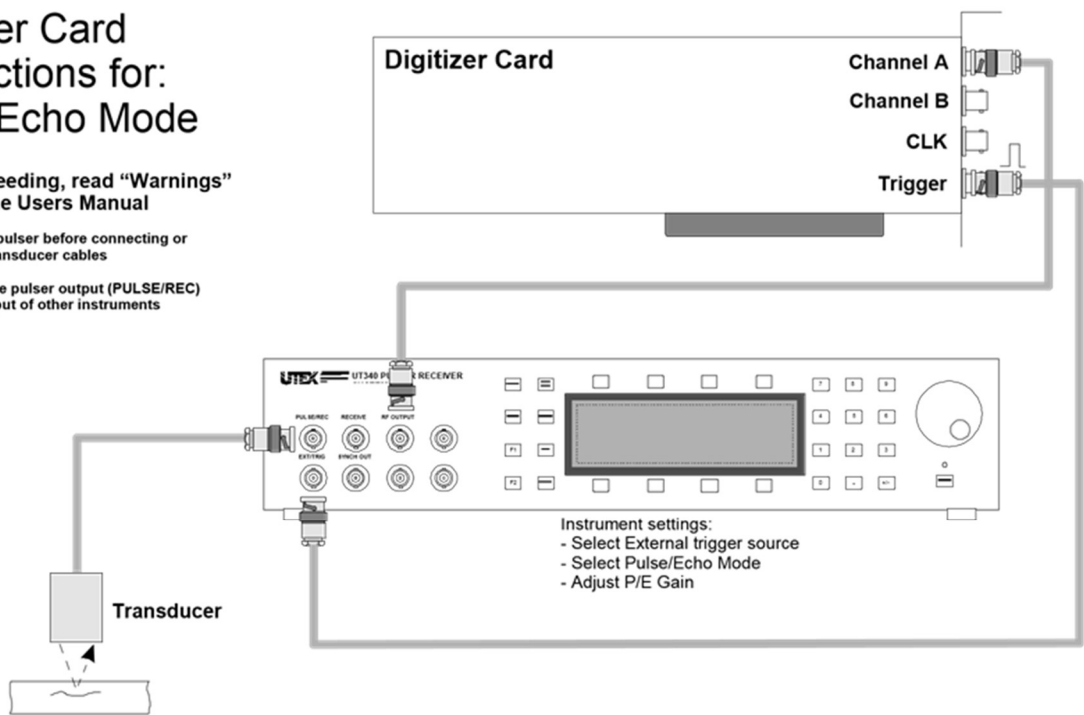

UT340 - Oscilloscope connections for: Pitch Catch Mode

Before proceeding, read "Warnings" section in the Users Manual

Always stop the pulser before connecting or disconnecting transducer cables

Never connect the pulser output (PULSE/REC) directly to the input of other instruments

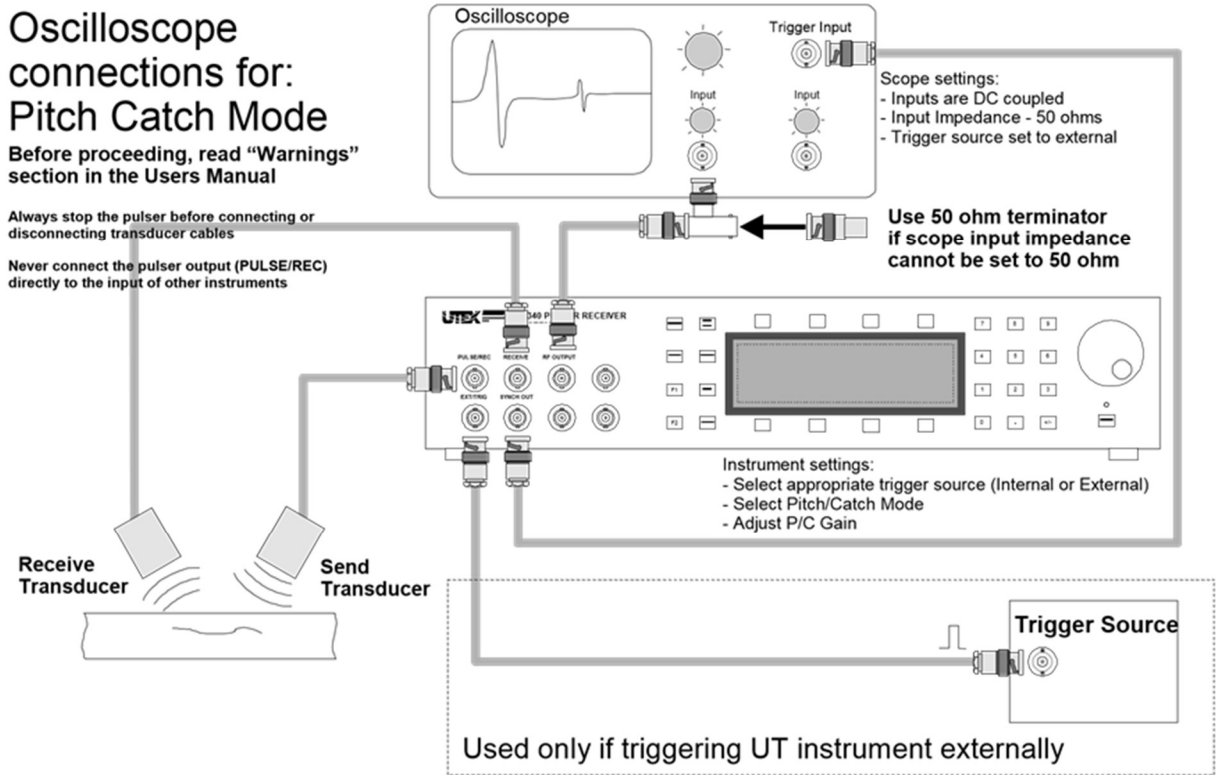

UT340 - Digitizer Card connections for: Pitch Catch Mode

Before proceeding, read "Warnings" section in the Users Manual

Always stop the pulser before connecting or disconnecting transducer cables

Never connect the pulser output (PULSE/REC) directly to the input of other instruments

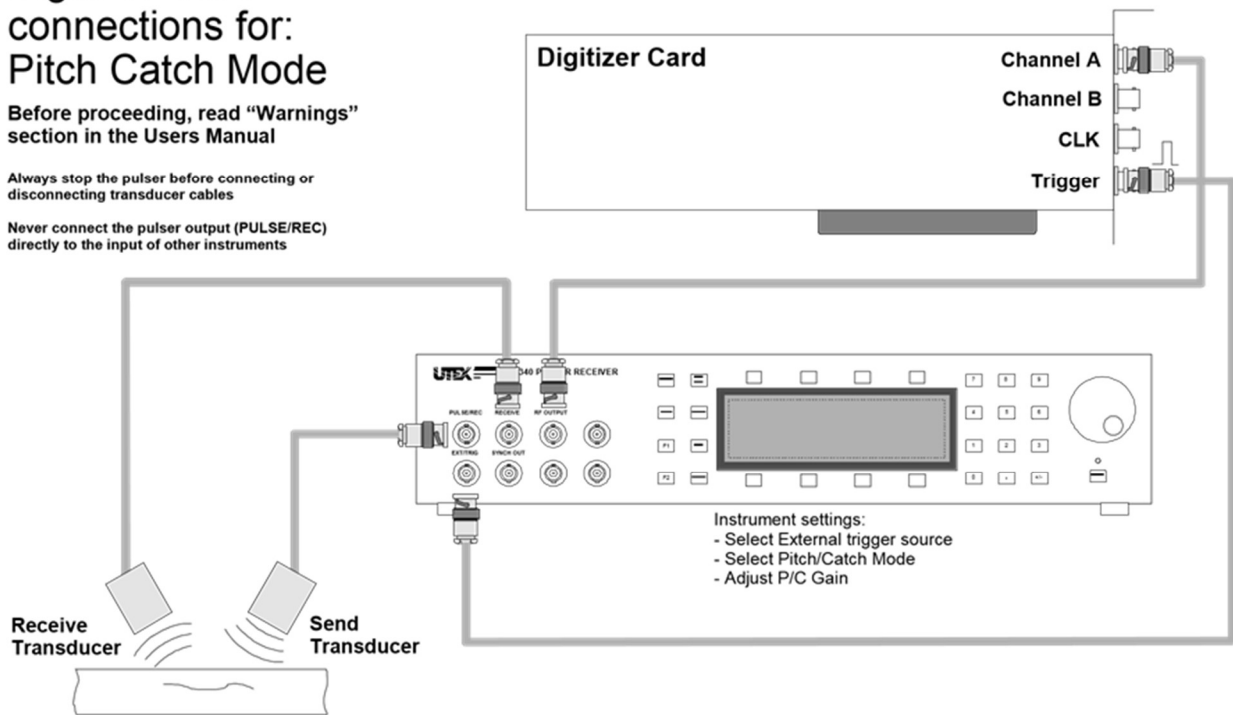

UT340 - Oscilloscope and Digitizer Card connections for Pulse Echo Mode

Before proceeding, read "Warnings" section in the Users Manual

Always stop the pulser before connecting or disconnecting transducer cables
Never connect the pulser output (PULSE/REC) directly to the input of other instruments

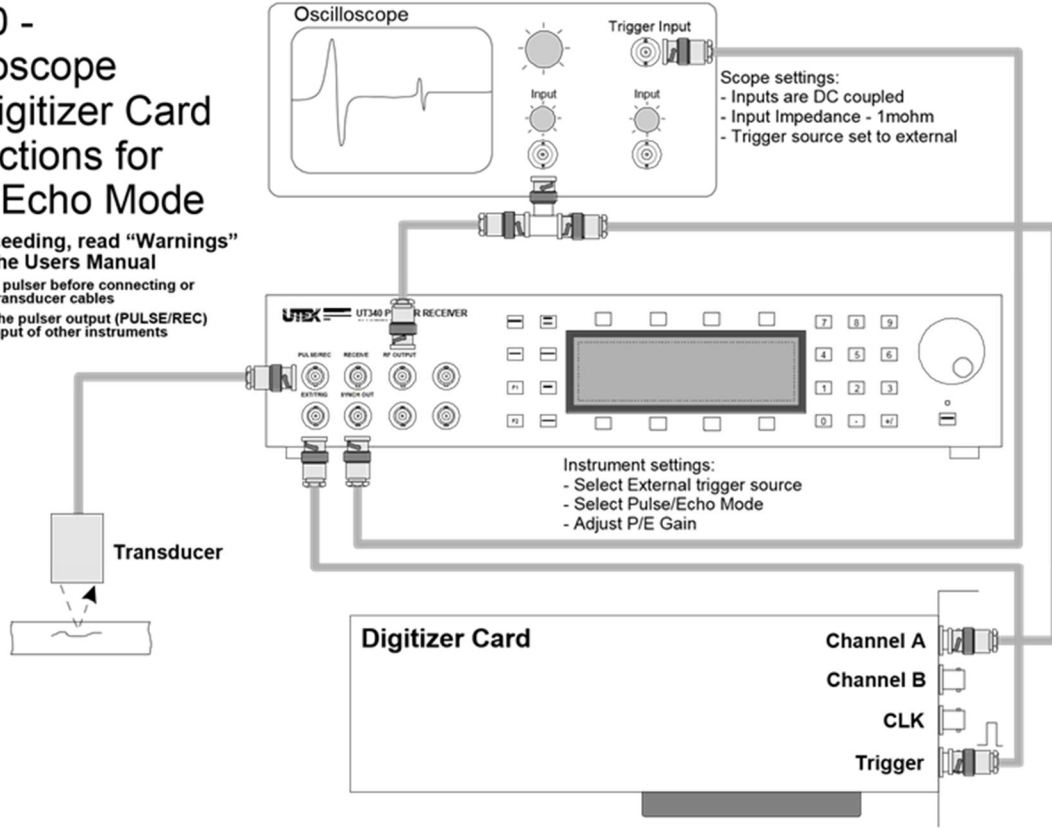

UT340 - Oscilloscope and Digitizer Card connections for Pitch Catch Mode

Before proceeding, read "Warnings" section in the Users Manual

Always stop the pulser before connecting or disconnecting transducer cables
Never connect the pulser output (PULSE/REC) directly to the input of other instruments

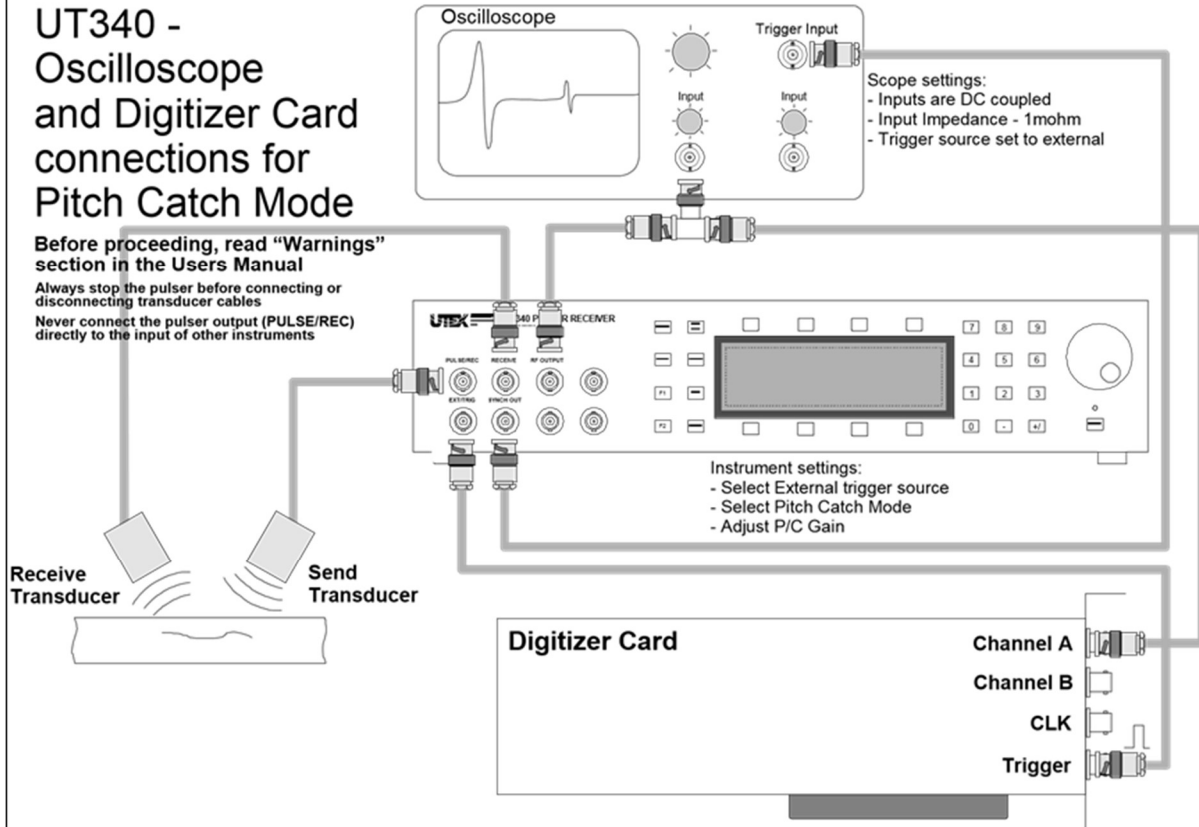

Introduction

SYSTEM OVERVIEW

The UTEX series of pulser receivers is designed to pulse and amplify ultrasonic transducers with center frequencies from 1MHz to 150MHz. Transducer excitation is achieved with an ultra-fast square wave pulser featuring adjustable pulse width and adjustable pulse voltage. The amplifiers in the instrument are directly gain controllable. This unique capability eliminates the need for attenuators that contribute to receiver noise.

Full computer control is possible using the included Windows™ interface software, optional Winspect™ data acquisition software or your own software.

MODES OF OPERATION

STAND ALONE OPERATION (UT340 ONLY)

The UT340 features one of the easiest to use front panels in the industry. Simply select the instrument mode (i.e. pulser) and then select the variable (i.e. pulse width).

Variables can be changed by rotating the front panel knob or by direct entry using the numeric keypad.

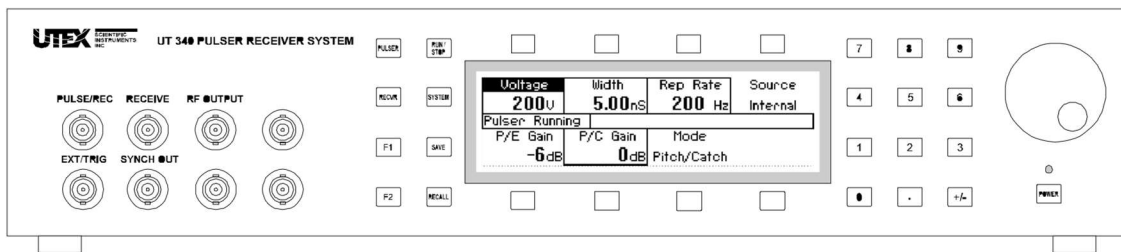

All instrument settings can be saved and recalled from 99 stored set-ups.

COMPUTER-CONTROLLED OPERATION (UT320 & UT340)

Both the UT320 and UT340 are shipped with Interface Software allowing for easy remote control of your instrument.

Computer control of the instrument can also be achieved by using simple ASCII serial commands via an RS-232 interface. For instance, the command PV450 would set the pulse voltage to 450V. Without exception, *all* instrument settings can be adjusted using simple serial commands.

The computer interface also acts in reverse. All changes made on the instrument front panel are automatically sent back to the computer using the same simple set of commands. This allows true copilot operation where both the front panel and the computer interface may control the instrument without having to perform remote/local switching. Both the instrument front panel and the computer interface are continually updated.

CONNECTING TO YOUR COMPUTER

Using the serial cable supplied with your instrument, connect from your computer's serial communications port to the RS-232 connector as shown in the drawing below:

If your computer uses a smaller 9-pin connector (notebooks) or a DIN connector (Mac), you may need to use a different cable or a conversion adapter. These adapters are readily available from computer retailers or you may already have received one with a serial mouse or other serial peripheral.

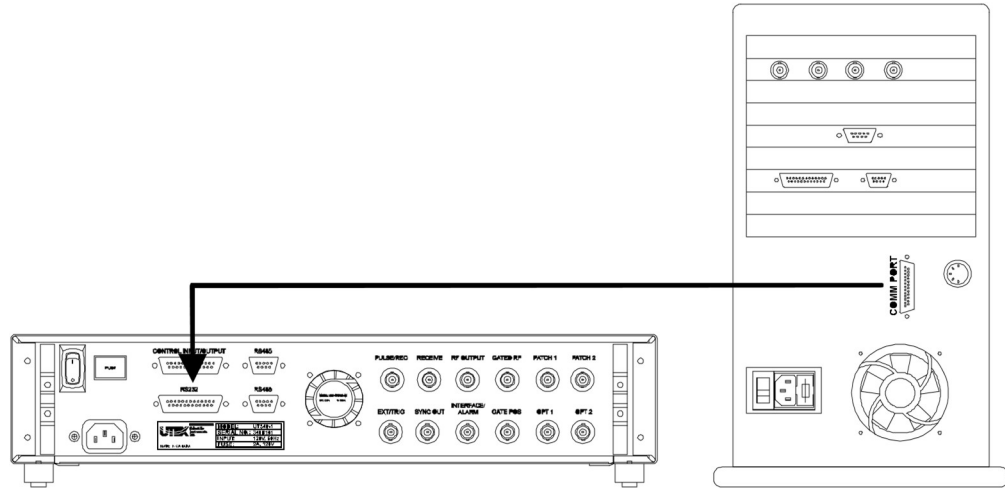

GETTING STARTED

FRONT PANEL CONTROLS (UT340 ONLY)

The UT340 front panel controls are logically grouped by function. The groups are: Instrument Mode Keys, Display Menu Keys, Graphics Display, Numeric Input Keys, Rotary Knob, Power Button and Power LED Indicator.

INSTRUMENT MODE KEYS

The instrument mode keys are used for selecting menus. The menus are logically grouped so that constant menu changing is not required. Most instrument control can be achieved by using the *Pulser* menu.

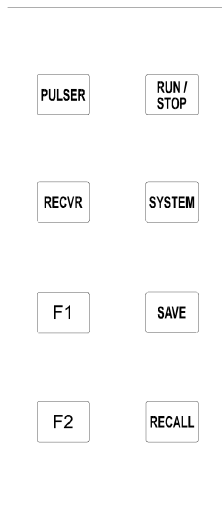

Instrument Mode Key	Function
PULSER	displays pulser and receiver settings
RECVR	displays only receiver settings
RUN/STOP	starts and stops the pulser
SYSTEM	displays system admin settings
SAVE	saves all instrument settings
RECALL	recalls all instrument settings
F1	for future use
F2	for future use

DISPLAY MENU KEYS

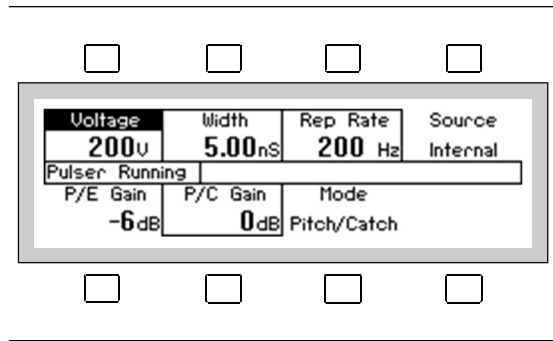

The four keys located above and below the display perform functions specific to the display label closest to each key. The keys are most often used for highlighting a variable such as “Voltage” so that its value can be changed later using the rotary knob or numeric entry keypad. They are also used for toggling the state of a variable such as switching from internal to external trigger.

NUMERIC INPUT KEYS

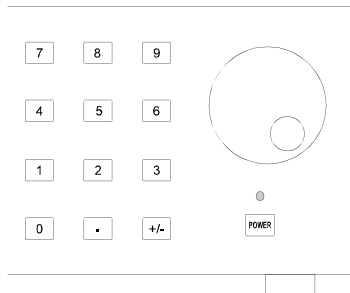

The first digit that is entered using the numeric keypad will cause the display to change to data input mode. Each digit will be accepted until the desired value is reached.

As shown below, the entry is completed by selecting one of the engineering units presented on the display such as ns.

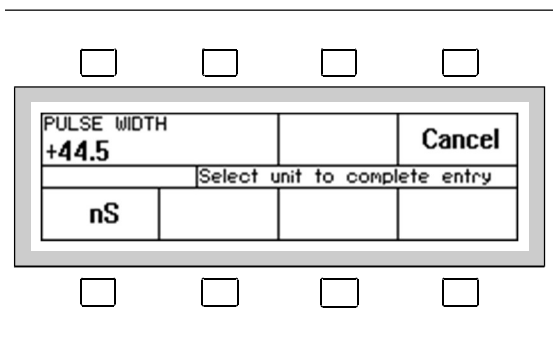

ROTARY KNOB

Turning the rotary knob will increase or decrease the value of the highlighted variable. Turning the rotary knob for more than one second will cause the rate of change to increase allowing for more rapid adjustment of the value of the selected variable.

POWER BUTTON AND INDICATOR LED

The front panel power button allows the user to turn the instrument power on and off.

The indicator LED is lit when the instrument power is on and flashes if the pulser is not running. The LED is lit continuously when the pulser is pulsing.

See page 17 for other messages provided by this indicator.

INSTRUMENT CONNECTORS

FRONT PANEL CONNECTORS

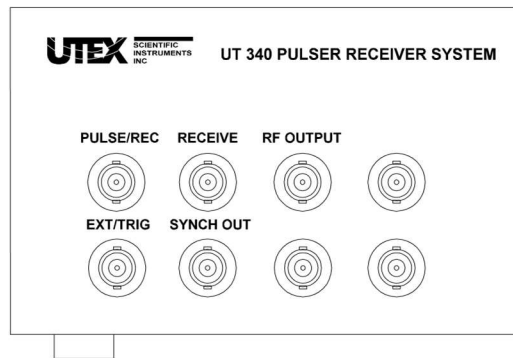

Front Panel Connector	Function
PULSE/REC	pulser output and pulse echo RF input
RECEIVE	pitch catch RF input only (↑ do not bridge ↑)
RF OUTPUT	amplified RF output to other instruments
EXT/TRIG	trigger input when in external trigger mode
SYNC OUT	trigger output which is in sync with the pulser
Blank Connectors	can be used for patching to the rear panel

REAR PANEL CONNECTORS

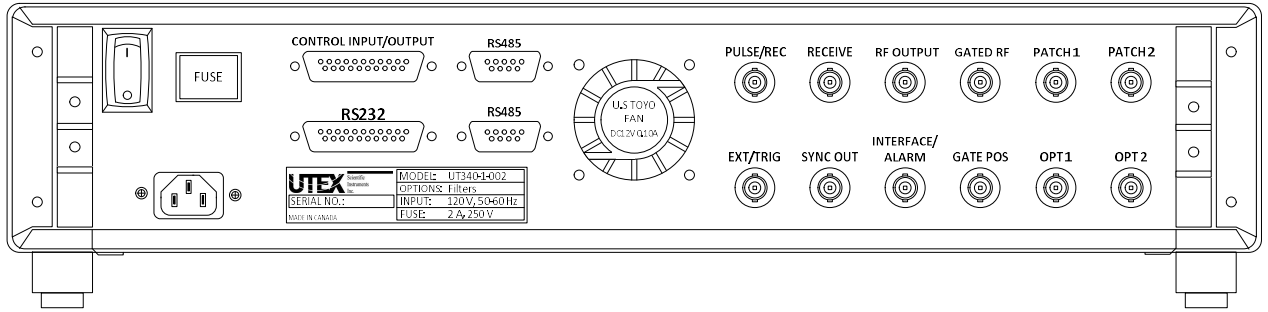

Rear Panel Connector	Function
Power Input Connector	AC power (voltage specification on serial tag)
RS-232	connection to the host computer (19.2 kBd) See page 63 for connector pin assignments.
CONTROL INPUT/OUTPUT	user defined relay contacts and digital I/O See page 63 for connector pin assignments.
PATCH 1 and PATCH 2	optional connection from rear to front panel*
Front Panel Duplicates	allows front panel signals to be moved to the back panel**

*The PATCH 1 and PATCH 2 connectors are used to route signals from the front panel out to the back panel. This requires that optional internal cables be installed by UTEX.

**The front panel “duplicates” are not connected on the back panel unless requested. All the signals, as a default are connected to the front panel connectors only. Signals can be connected to the front or the back at no additional charge at the time of order. If you would like to have them moved from the front to the back at a later date, please contact UTEX for a quote.

TURNING THE INSTRUMENT ON AND OFF

USING THE UT340 FRONT PANEL POWER BUTTON

The front panel power button is intended for everyday use. It places the instrument into Standby mode whereby major components such as the display and the pulser are powered down.

The computer, however, remains active and is still able to receive and send serial commands. It is, therefore, possible to turn the instrument power *off and on* using serial port commands.

USING THE UT320 FRONT PANEL POWER BUTTON

When the power is turned off using this switch, the instrument will not be able to accept or receive serial port commands regardless of whether the rear panel switch is on or off.

USING THE REAR PANEL POWER SWITCH

The rear panel power switch is not intended for everyday use, although, no harm will come to the instrument if it is used.

Leaving this power switch on has two advantages:

1. UT340 model instruments can be turned on and off remotely, using serial port commands.
2. UT320 and UT340 units shipped prior to 1998 have a rechargeable backup battery, which will remain charging as long as the rear panel power switch is on.

POWER AND STATUS LED

The power LED indicator serves several functions in addition to indicating that the instrument is switched on. The following table indicates how the flashing of this indicator should be interpreted:

State of the Power LED	Implied Message
off	instrument is not turned on
on (steady)	pulser is running
flashing slowly	pulser is not running
flashing 2 times per second	over-voltage error detected
flashing 4 times per second	over-current error detected
flashing 8 times per second	FLASH memory is being reprogrammed

POSSIBLE ERRORS

Should any error occur when turning your instrument on, disconnect all front panel instrument cables and try again. Should the error occur again, please contact UTEX technical support. See the section “System Messages” on page 33 for more information.

WINDOWS™ SOFTWARE INTERFACE OVERVIEW

The control software included with these pulser receivers can be used to remotely control and configure the instrument. All instrument variables can be controlled and saved to a USB key using this Windows™-based interface. Full instructions on its installation and use can be found in the “Windows™ Software Interface” section on page 25.

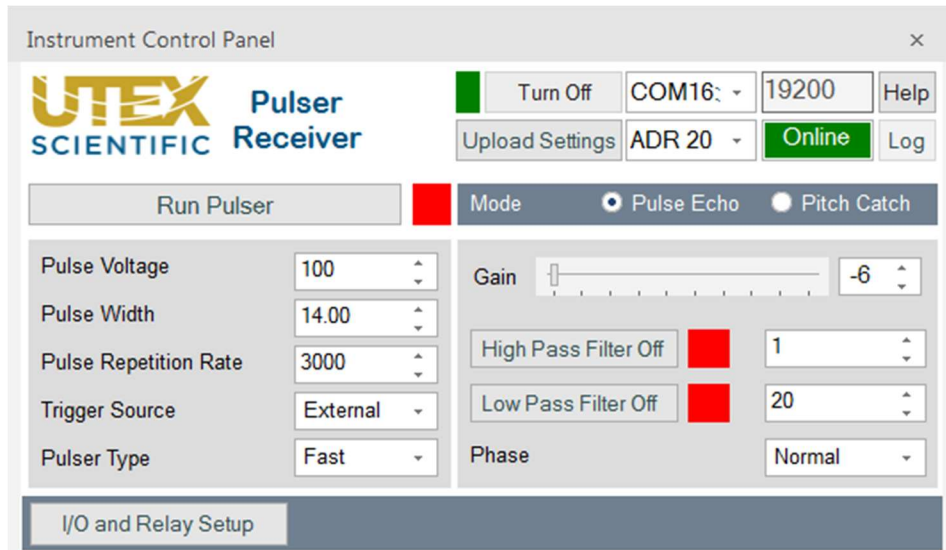

CONTROLLING THE INSTRUMENT

PULSER MODE SETTINGS (UT340 ONLY)

Pressing the PULSER mode key will display the menu shown below.

The Pulser Mode Menu is probably where you will spend most of your time operating the instrument. Some receiver variables are also placed on this menu for convenience.

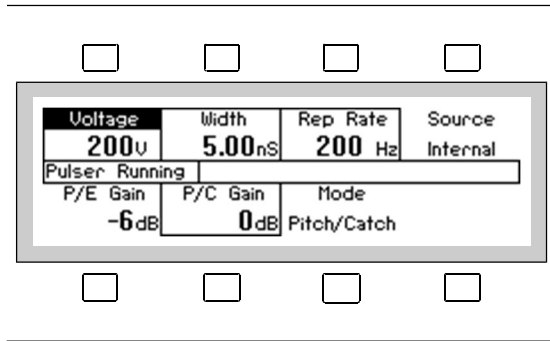

Display Menu Key	Function
Voltage	selects Pulse Voltage setting
Width	selects Pulse Width setting
Rep Rate	selects Pulse Rep Rate setting
Source	toggles between Internal and External Trigger
P/E Gain	selects Pulse/Echo Gain setting
P/C Gain	selects Pitch/Catch Gain setting
Mode	toggles between Pitch/Catch and Pulse/Echo

STARTING AND STOPPING THE PULSER

The Run/Stop key starts and stops the pulser. During the pulser “soft start” sequence, the display will indicate “Pulser Starting” followed shortly by “Pulser Running”.

During the start-up sequence, the pulser will have confirmed that the impedance seen by the pulser is not dangerously low (short circuit) or extremely capacitive. It is because of this feature that we suggest stopping the pulser whenever transducer cables are removed or connected.

RECEIVER MODE SETTINGS

Pressing the RECVR mode key will display the menu shown below.

The Receiver Mode Menu contains only receiver functions. This is useful when operating with fixed pulser settings where, for example, accidental adjustment of the pulser voltage could damage the transducer.

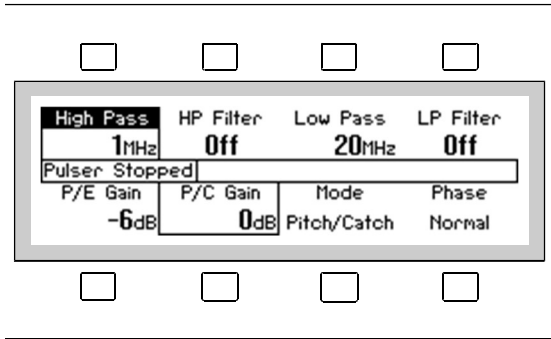

Display Menu Key	Function
High Pass	selects High Pass setting
HP Filter	toggles high pass filter On and Off
Low Pass	selects Low Pass setting
LP Filter	toggles low pass filter On and Off
P/E Gain	selects Pulse/Echo Gain setting
P/C Gain	selects Pitch/Catch Gain setting
Mode	toggles between Pitch/Catch and Pulse/Echo
Phase	toggles between Normal and Inverted RF output

SYSTEM SETTINGS

Pressing the SYSTEM mode key will display the menu shown below.

The System Settings Mode contains general instrument control functions.

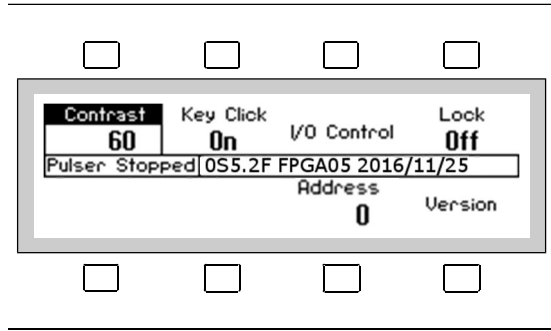

Display Menu Key	Function
Contrast	selects the display Contrast setting
Key Click	enables or disables audible Key Beeps
I/O Control	transfers to the sub-menu for I/O controls
Lock	enables or disables instrument adjustments
Address	selects the Address setting
Version	displays the current Version of the software

I/O CONTROL SETTINGS

Pressing the I/O menu key while in the SYSTEM menu will display the menu shown below. The I/O Control Settings Mode contains TTL I/O line and Relay output control functions for the instrument.

Note that only the default labels are shown. Since the captions for I/O lines and Relays can be user defined, they may be labelled differently on your instrument.

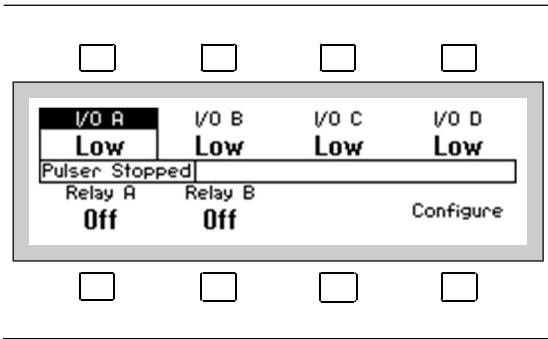

Display Menu Key	Function
I/O A	changes the state of the I/O A digital line
I/O B	changes the state of the I/O B digital line
I/O C	changes the state of the I/O C digital line
I/O D	changes the state of the I/O D digital line
Relay A	changes the state of Relay A
Relay B	changes the state of Relay B
Configure	shows configuration sub-menu for the current I/O

I/O SETTING CONFIGURATION

Pressing the “Configure” menu key while in the I/O sub-menu will display the menu shown below.

This shows the configuration for the I/O control that is highlighted in the I/O sub-menu. The name of the I/O control will appear in the center message window. While in this mode, changes can be made to customize the control to suit your needs.

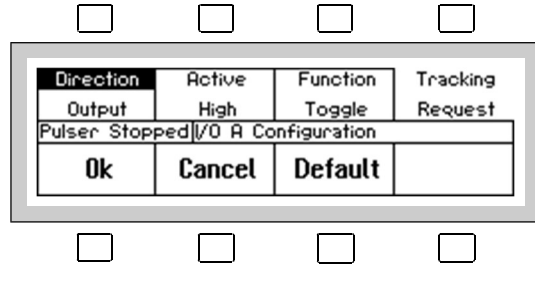

Display Menu Key	Function
Direction	toggles between Input and Output
Active	toggles between High and Low when direction is output
Invert	toggles between Yes and No when direction is set as an Input
Function	toggles between Toggle and Momentary
Tracking	toggles between Auto and Request
OK	accepts all configuration changes
Cancel	aborts any configuration changes
Default	restores configuration to the factory default

WHEN THE INSTRUMENT INTERVENES

The pulser receiver will take over control of the instrument when you ask for combinations of variables that might damage either the transducer or the instrument. The pulser monitors the average power being delivered to the load, the average voltage at the output and the pulse peak current.

Situation Causing Intervention	Action Taken by the Instrument
more than 10 Amps delivered to load	pulser stopped
more than 3 Watts average to load	last selected variable is rolled back
irrationally high average voltage at load	pulser stopped, high voltage disabled

SAVE AND RECALL OPTIONS

SAVING INSTRUMENT SETTINGS

By pressing the "Save" key, the instrument will prompt you to enter a two digit storage location. You may choose any location from 00 to 99. All instrument settings are saved to this location for retrieval at a later time.

RECALLING INSTRUMENT SETTINGS

By pressing the "Recall" key, the instrument will prompt you to enter a two digit storage location. As with saving, you may choose any location from 00 to 99. All instrument settings are recalled from this location, restoring the instrument to the settings saved earlier.

The pulser is never enabled after a recall so that you may confirm that the pulser settings are safe for the current transducer. Just press Run/Stop to restart the pulser.

If you attempt to recall settings from an empty storage location (no previous saves), all variables will be set to their minimum values.

FUNCTION KEY ASSIGNMENTS

The F1 and F2 keys may be custom programmed by UTEX to perform specific user-specified functions.

WINDOWS™ SOFTWARE INTERFACE

UTEXUT WINDOWS™ SOFTWARE INTERFACE INSTALLATION

MINIMUM REQUIREMENTS

- 32 or 64 bit versions of Windows 7™, Windows 8™, or Windows 10™
- VGA color Monitor
- 100 MB of Memory
- CD Drive or Internet connection
- 1 GB of available hard disk space

INSTALLATION INSTRUCTIONS

Install the UTEX Instrument Interface by following these steps:

1. Place the UTEX INTERFACE CD into the Disk drive
2. Run the CD
3. Follow the instructions on the screen

MAIN CONTROL PANEL

When the UTEX Instrument Interface is first started, the program waits for a connection to be established with the instrument. The following screen will be displayed until the serial cable is connected, the instrument power is switched on, and the correct com port is selected by the user.

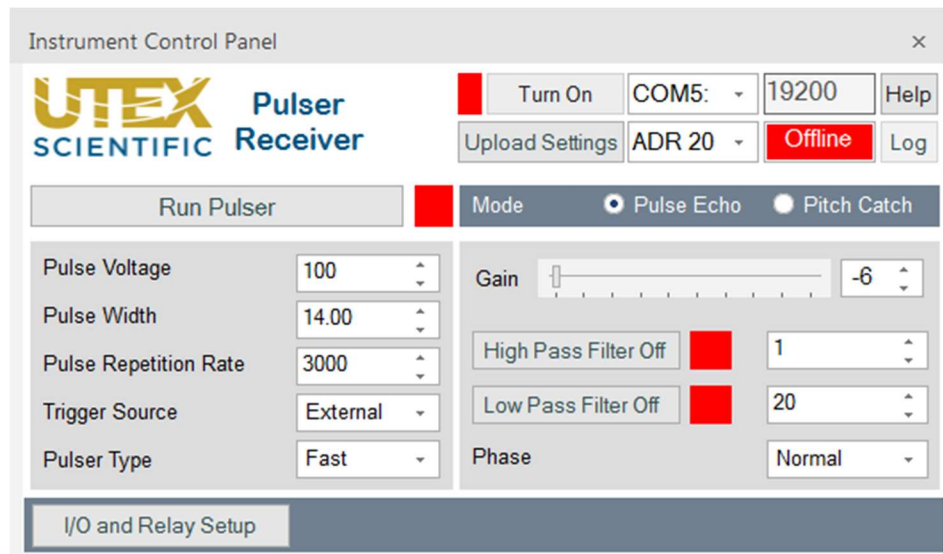

Once the connection is established, the red “Offline” will change to a green “Online”. All of the instrument settings are sent to the PC and all sliders and spinners are adjusted to match the instrument’s current operating conditions.

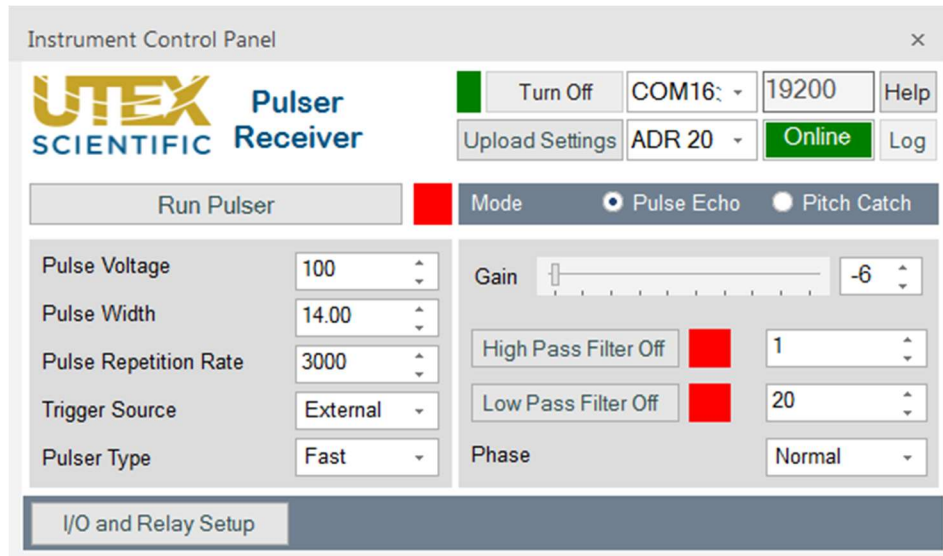

INSTRUMENT POWER BUTTON

Pressing the “Turn Off” or “Turn On” button is the same as pressing the front panel power button on the UT340. It is intended for everyday use. It places the instrument into standby mode whereby major components such as the display and the pulser are powered down.

The computer, however, remains active and is still able to receive and send serial commands. When the instrument is on, the coloured square to the left of the button will be green and will read “Turn Off”. When the instrument is off, the coloured square to the left of the button will be red and will read “Turn On”.

COM PORT

The drop down menu for the COM port allows up to 48 different COMs. The user must select the COM port that corresponds to the connected Pulsar Receiver.

BAUD RATE

The BAUD Rate is indicated beside the COM port. Currently, the instrument supports only 19200 BAUD and cannot be changed.

HELP

The help button will open a copy of this manual in PDF format.

UPLOAD SETTINGS

Pressing the Upload Settings button will take all the setting from the UT340 and set them to the UI. If an error is encountered while the changes are being sent to the instrument, it will appear in the Diagnostics window. Use the Upload Settings button to ensure the current instrument setting.

ADDRESS CHANGE

To change the address of the instrument, press the down arrow and select address ADR 0 through ADR 32. On UI launched the current address will be indicated by the ADR number.

LOG

Clicking the Log button opens a window to view any errors that may have occurred. In this window it allows you to save any message or clear them.

ABOUT SPINNERS

All spinners allow the selected variable to be adjusted from the minimum to maximum setting in incremental steps. Clicking the spinner arrows increases or decreases the variable in the smallest available step size. Holding an arrow in either direction will speed up the rate that the spinner increments.

Clicking the number will highlight it and allow it to be edited to any value within its range. If the value entered is below the lower limit, the spinner will be set to the minimum value. If the value entered is above the upper limit, the spinner will be adjusted to the maximum value.

PULSER CONTROLS

PULSE VOLTAGE SPINNER

The "Standard" pulser allows the voltage to be adjusted from 100 volts to 500 volts in 2 volt steps. The "Fast" pulser allows the voltage to be adjusted from 100 volts to 250 volts in 2 volt steps. The "Wide"* pulser allows the voltage to be adjusted from 100 volts to 500 volts in 2 volt steps.

*(*not available at time of printing)*

PULSE WIDTH SPINNER

The "Standard" pulser can have the pulse width adjusted from 5 ns to 80 ns. Between 5 ns and 45 ns the spinner increments in 0.5 ns steps, and from 45 ns to 80 ns the spinner increments in 0.2 ns steps.

The "Fast" pulser can have the pulse width adjusted from 2.00 ns to 71.75 ns. Between 2.00 ns and 18.00 ns the spinner increments in 0.4 ns, and from 18.00 ns to 71.75 ns the spinner will increment in 0.25 ns steps.

The "Wide"* pulser can have the pulse width adjusted from 5.4 ns to 248.00 ns. Between 5 and 31 the spinner increments in 2 ns steps, and from 31.00 ns to 248.80 ns it increments in 0.9 ns steps. *(*not available at time of printing)*

PULSE REPETITION FREQUENCY SPINNER

The pulse Repetition Frequency Spinner (PRF) allows the PRF to be adjusted from 200 Hz to 20,000 Hz (20 kHz).

TRIGGER SOURCE

The drop down menu can be opened to change between Internal and External Trigger. This allows the source of the PRF to be controlled by the instrument's internal generator or by an external trigger source. When the trigger source is changed while the pulser is running, the pulser will be stopped and restarted using the alternate trigger. This ensures that if the PRF is too high the instrument will be able to compensate.

RUN PULSER

This button starts and stops the pulser. When the pulser is running, this button is green and the text reads "Stop Pulser". When the pulser is stopped, this button is red and the text reads "Run Pulser".

RECEIVER CONTROLS

GAIN SLIDER

The Gain Slider allows the receiver gain to be adjusted from -6 to 57 dB in Pulse Echo mode or 0 to 63 dB in Pitch Catch mode in 1 dB steps.

RECEIVER MODE

The two bullets for Pulse Echo and Pitch Catch are used to select a pulser mode of pulse and receive on the same transducer (Pulse Echo) or pulse on one transducer and receive on another (Pitch Catch).

FILTER CONTROLS BUTTON (FOR MODELS WITH FILTER OPTION ONLY)

If your pulser receiver has the optional filter module, pressing the Filter Controls button will expand the main panel to display the filter control functions along the bottom of the main panel. If either of the filters is on, this button will be green. For details, see the following page.

I/O AND RELAY SETUP

Pressing the I/O and Relay Setup button will expand the main panel to display the I/O control functions along the bottom of the main panel. For details, see page 30.

FILTER CONTROLS (FOR MODELS WITH FILTER OPTION ONLY)

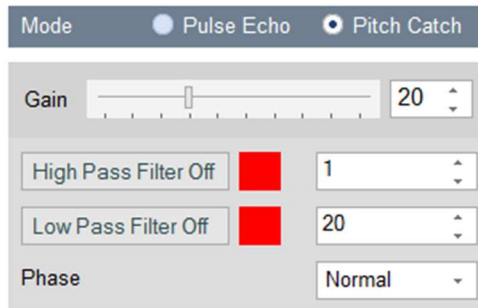

HIGH PASS FILTER SPINNER

The High Pass Filter Spinner allows the cut-off frequency of the high pass filter to be adjusted from 1 MHz to 20 MHz in 1 MHz steps.

HIGH PASS FILTER BUTTON

This button turns the high pass filters on and off. When the high pass filter is turned on, the button turns green (from red) and the label for the button will change from “OFF” to “ON”.

LOW PASS FILTER SPINNER

The Low Pass Filter Spinner allows the cut-off frequency of the low pass filter to be adjusted from 20 MHz to 150 MHz in 1 MHz steps.

LOW PASS FILTER BUTTON

This button turns the low pass filters on and off. When the low pass filter is turned on, the button turns green (from red) and the label for the button will change from “OFF” to “ON”.

PHASE CONTROL

The drop down menu across from “Phase” can be used to control whether the phase of the signal at the RF Output on the front panel is normal or inverted.

I/O AND RELAY SETUP

To access the Input/Output controls, press the I/O Relay Stop button. The main panel will expand to display the I/O control functions along the bottom of the main panel.

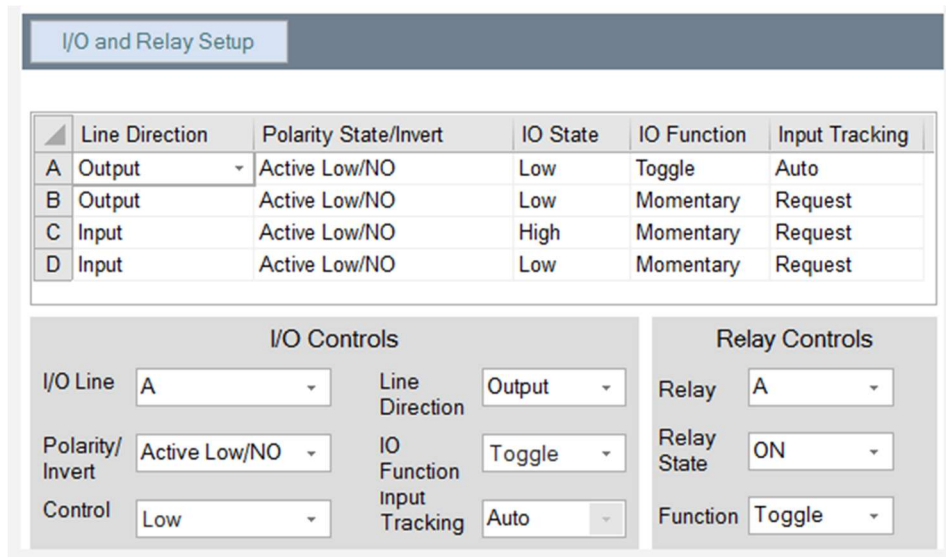

I/O CONTROLS

I/O LINES

The drop down list can be used to select one of the four line directions (A to D). Once the desired line direction is selected, the other settings can be changed and they will only affect the selected line.

LINE DIRECTION

The drop down list can be used to change between “Input” and “Output” control whether the TTL I/O line is to be used as an input or as an output. When set as an input the IO Function and Control options for the selected line are disabled.

POLARITY/INVERT

The drop down list can be used to select “Active Low/NO” or “Active High/YES”. If “Active High/YES” is selected then the signal on the input pin will be +5 volts.

I/O FUNCTION

The drop down list can be used to change between “Momentary” and “Toggle” to control how the button for the Line Direction or Relay line functions. When set to Momentary, the button will change the state of the output pin. When the button is released, the output pin will change back to the previous state. This function is only applicable when Line Direction is set as an Output.

CONTROL

The drop down list can be used to change between “High” and “Low”. This function is only applicable when Line Direction is set as an Output.

INPUT TRACKING

The drop down list can be used to change between “Request” and “Auto”. This function is only applicable when Line Direction is set as an Input.

RELAYS

RELAY

The drop down list can be used to select Relay A or Relay B. Once the desired relay is selected the other settings can be changed and they will only affect the selected relay.

RELAY STATE

The drop down list can be used to select “OFF” or “ON”. These options control whether the relay contact closes or opens when the button on the I/O control panel is pressed.

FUNCTION

The drop down list can be used to change between “Momentary” and “Toggle”.

MESSAGE WINDOW

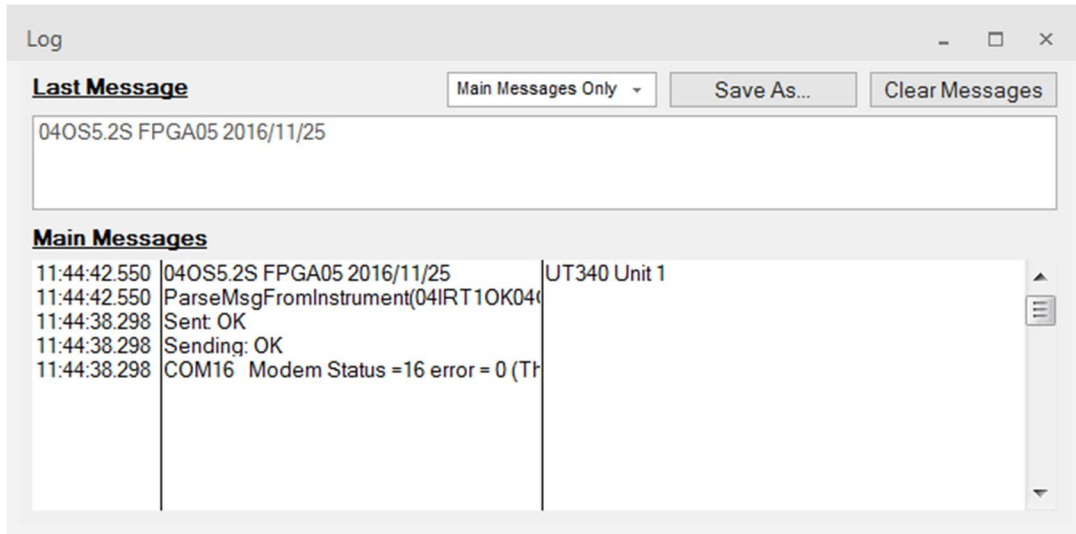

Clicking the Log button opens this window. These messages may contain start-up information, error messages or information about adjustments that the instrument has made on its own to stay within safe operating limits. The amount of messages received can be chosen by using the drop down menu and selecting "Main Messages Only", "Most Messages", or "All Messages".

Please see the "System Messages" section of this manual on page 33.

SYSTEM MESSAGES

INSTRUMENT SYSTEM MESSAGES

Problem Message	Action Taken Message	Reason
Max Power	pulse voltage limited	average power was too high
Max Power	pulse width limited	average power was too high
Max Power	internal PRF limited	average power was too high
Max Power	external PRF limited	average power was too high
Max Power	system shut off	could not resolve using limiting
Max Power	fatal error while idle	system error
Pulser Max Power	system shut off	pulser error
Over Current	system shut off while running	load impedance too low
Over Current	system shut off	system error
Over Current	fatal error while idle	system error
Over Current	system shut off	pulser error
Over Voltage	system shut off while running	unusual voltage present at load
Over Voltage	system shut off	system error
Over Voltage	fatal error while idle	external voltage present
Over Voltage	system shut off	pulser error
Invalid Increment	value rounded	input value was not a valid step
Value Out Of Range		input value was out of range
Invalid Command		serial command not supported
LCD Not Found		unable to find display
System Error		fault located by diagnostics

Voltage Corrupted	set to minimum	RAM variable was irrational
PRF Corrupted	set to minimum	RAM variable was irrational
P/E Corrupted	set to minimum	RAM variable was irrational
P/C Corrupted	set to minimum	RAM variable was irrational

SPECIFICATIONS

The UTEX pulser receiver instruments are comprised of a series of high-performance modular components. These components include a high-frequency, high-power pulser and low-noise wideband amplifiers under full digital control.

PULSER

The UTEX high-frequency pulser can vary pulse width and pulse voltage. It is suitable for extremely high-power and high-frequency work. A peak pulse power of 5.0 kilowatts is available with available pulse energy from 1 to 350 μ Joules. Because of its variable pulse width, this pulser is tuneable to drive a large range of transducers of different frequencies most effectively.

Pulse Specification	Risetime	<2.0 ns
	Falltime	<2.0 ns
	Ideal Load Impedance	50 ohms
	Minimum Load Impedance	capacitive load to 10 Amps
Pulse Voltage Control	Output Voltage Minimum	100 V
(Standard Pulser)	Output Voltage Maximum	500 V
	Voltage Increment	2 V
Pulse Voltage Control	Output Voltage Minimum	100 V
(Fast Pulser)	Output Voltage Maximum	250 V
	Voltage Increment	2 V
Pulse Voltage Control	Output Voltage Minimum	100 V
(Wide Pulser)*	Output Voltage Maximum	500 V
	Voltage Increment	2 V
Pulse Width Control	Pulse Width Minimum	5.0 ns
(Standard Pulser)	Pulse Width Maximum	80 ns
	Pulse Width Resolution	200 ps and 500 ps
	Pulse Width Accuracy	10%
Pulse Width Control	Pulse Width Minimum	2.0 ns
(Fast Pulser)	Pulse Width Maximum	71.75 ns

	Pulse Width Resolution	250 ps and 500 ps
	Pulse Width Accuracy	10%
PRF Control	PRF Minimum	200 Hz
	PRF Maximum	20 kHz
	<i>*not yet available</i>	

WIDEBAND RECEIVER AMPLIFIER

Each internal wideband amplifier stage can alter its gain so that any combination of gains can be achieved without attenuation. When relatively large signals are being amplified, the total gain is reduced, thus dramatically improving the signal-to-noise ratio.

Gain Specification	Bandwidth (-3dB)	1 MHz to 150 MHz
	Equivalent Input Noise	100 μ V p-p max
	Maximum Output Level	0 dBm
	Output Headroom	6 dB
Gain Control P/C	Voltage Gain Minimum	0 dB
	Voltage Gain Maximum	63 dB
	Gain Increment	1 dB
Gain Control P/E	Voltage Gain Minimum	-6 dB
	Voltage Gain Maximum	57 dB
	Gain Increment	1 dB

CONTINUOUSLY VARIABLE FILTERS

The High Pass and Low Pass filters can vary their cut-off frequencies independently.

Low Pass Filter	Frequency Range	20 MHz to 150 MHz
	Resolution	1 MHz
	Cut-off Slope	12 dB/octave
	Passband Ripple	None
	Insertion Loss	0 dB
	Filter Bypass	Yes
High Pass Filter	Frequency Range	1 MHz to 20 MHz
	Resolution	1 MHz
	Cut-off Slope	12 dB/octave
	Passband Ripple	None
	Insertion Loss	0 dB
	Filter Bypass	Yes

INSTRUMENT INTERFACE

Interface	RS-232 (to host computer)	19.2 KBaud
	RS-485 (to linked pulser receivers)	19.2 KBaud

COMMAND STRUCTURE OVERVIEW

This command summary lists only the commands that are available to the user through serial communications. All characters transmitted and received are in ASCII format.

The minimum and maximum values as well as the increment size reflect the beta release hardware configuration. Maximum values may have been limited for reasons of safety or reliability.

Pulser Functions	Command	Minimum Value	Maximum Value	Increment Size	Default Units	Supported Units
Over-Current Reset	OCR	-	-	-	-	-
Over-Voltage Reset	OVR	-	-	-	-	-
Pulse Repetition Frequency	PRF	200	20000	VARIABLE	Hz	Hz,kHz
Pulse Voltage	PV	100	500	2	V	V
Pulse Width	PW	5	80.00	VARIABLE	ns	ns,µs
Pulser Run/Stop	PON	0	1	-	0 or 1	0 or 1
Trigger Source External	TSE	-	-	-	-	-
Trigger Source Internal	TSI	-	-	-	-	-

Receiver Functions	Command	Minimum Value	Maximum Value	Increment	Default Units	Supported Units
Filter Output Mode	FIN	0	1	-	0 or 1	0 or 1
High Pass Filter	HPF	1	20	1	MHz	MHz
High Pass Filter Enable	FHE	0	1	-	0 or 1	0 or 1
Low Pass Filter	LPF	20	150	1	MHz	MHz
Low Pass Filter Enable	FLE	0	1	-	0 or 1	0 or 1
Receiver Gain (current mode)	RG	0/-6	63/57	1	dB	dB
Receiver Gain (pitch catch mode)	PCG	0	63	1	dB	dB
Receiver Gain (pulse echo mode)	PEG	-6	57	1	dB	dB
Receiver to Pitch Catch Mode	RPC	-	-	-	-	-
Receiver to Pulse Echo Mode	RPE	-	-	-	-	-

System Control Functions	Command	Minimum Value	Maximum Value	Increment	Default Units	Supported Units
Address	ADR	0	32	1	-	-
Designation	DSG	0	1	-	0 or 1	0 or 1
Flow Control	FCE	0	1	-	0 or 1	0 or 1
Initialize Thermostat	IT	-	-	-	-	-
Lock	SL	0	1	-	0 or 1	0 or 1
Refresh	REFH	-	-	-	-	-
Retransmission Status	SRT	0	1	-	0 or 1	0 or 1
System Power On/OFF	SP	0	1	-	0 or 1	0 or 1
System Settings	OK	-	-	-	-	-
System Temperature	GST	-	-	-	-	-

I/O Control Functions	Command	Minimum Value	Maximum Value	Increment	Default Units	Supported Units
Relay A Control	RLA	0	1	-	0 or 1	0 or 1
Relay A Function	RAF	0	1	-	0 or 1	0 or 1
Relay A Name	RAN	''	9 characters	-	0 or 1	0 or 1
Relay A Polarity	RAP	0	1		Relay A	-
Relay B Control	RLB	0	1	-	0 or 1	0 or 1
Relay B Function	RBF	0	1	-	0 or 1	0 or 1
Relay B Name	RBN	''	9 characters	-	0 or 1	0 or 1
Relay B Polarity	RBP	0	1		Relay B	-
TTL Line A Control	IOA	0	1	-	0 or 1	0 or 1
TTL Line A Direction	TAD	0	1	-	0 or 1	0 or 1
TTL Line A Function	TAF	0	1	-	0 or 1	0 or 1
TTL Line A Name	TAN	''	9 characters	-	0 or 1	0 or 1
TTL Line A Polarity	TAP	0	1		I/O A	-
TTL Line A Tracking	TAT	0	1	-	0 or 1	0 or 1
TTL Line B Control	IOB	0	1	-	0 or 1	0 or 1
TTL Line B Direction	TBD	0	1	-	0 or 1	0 or 1
TTL Line B Function	TBF	0	1	-	0 or 1	0 or 1
TTL Line B Name	TBN	''	9 characters	-	0 or 1	0 or 1
TTL Line B Polarity	TBP	0	1		I/O B	-
TTL Line B Tracking	TBT	0	1	-	0 or 1	0 or 1
TTL Line C Control	IOC	0	1	-	0 or 1	0 or 1
TTL Line C Direction	TCD	0	1	-	0 or 1	0 or 1
TTL Line C Function	TCF	0	1	-	0 or 1	0 or 1
TTL Line C Name	TCN	''	9 characters	-	0 or 1	0 or 1
TTL Line C Polarity	TCP	0	1		I/O C	-
TTL Line C Tracking	TCT	0	1	-	0 or 1	0 or 1
TTL Line D Control	IOD	0	1	-	0 or 1	0 or 1
TTL Line D Direction	TDD	0	1	-	0 or 1	0 or 1
TTL Line D Function	TDF	0	1	-	0 or 1	0 or 1
TTL Line D Name	TDN	''	9 characters	-	0 or 1	0 or 1
TTL Line D Polarity	TDP	0	1		I/O D	-
TTL Line D Tracking	TDT	0	1	-	0 or 1	0 or 1

LCD Controls	Command	Minimum Value	Maximum Value	Increment	Default Units	Supported Units
Contrast Control	CON	0	127	1	-	-

Each of the system commands can be modified to provide additional information to the instrument.

System number, module number, polling and units are optional and can be used in any combination. The syntax relies on alternating numeric, alpha, numeric, alpha etc. fields that are not separated by spaces or delimiters. Module numbers are separated by the hatch (#) character.

If units are not specified in the command, the default unit for the command is used. Not all variables allow optional units.

Command Type	Syntax	Example String	Explanation
Single Instruction Command	CMD	TSE	Set trigger source to external generator.
Followed by Switch Value	CMDn	PON1	Start the pulser.
Followed by Variable Value	CMDn	PV100	Set the pulse voltage to 100V.
Preceded by System Number	sCMD	2PV100	Set the pulse voltage on unit 2 to 100V.
Followed by Module Number and Value	CMD#m#n	PV#1#100	Set the pulse voltage on module 1 to 100V.
Variable Polling	CMD?	PV?	Will return the current pulse voltage
System, Module and Value Specified	sCMD#m#n	2PV#1#100	Set the pulse voltage on module 1 of unit 2 to 100V.
Alternate Units Specified	CMDnu	PW100US	Set the pulse width to 100 μ S.

More than one command can be specified at a time. The commands are buffered and executed after a linefeed is received or a time-out of approximately 3 ms, whichever comes first.

The commands can be separated from each other by semicolons (;) or spaces. One command followed by a linefeed is also acceptable. The command buffer is limited to 64 characters including spaces and semicolons.

COMMUNICATIONS PROTOCOL

The two modes of operation for the RS-232 serial communications are command pacing and hardware flow control.

In command pacing mode, there are delays placed between the sending of commands. During the processing of any command, serial communications are disabled until the command is finished executing. For example, if the pulse width was set to the minimum value and a command was sent to change it to the maximum value, the instrument takes approximately 500 ms to accomplish this task. This time includes parsing the serial command, checking the limits, checking the step size and ramping the value up one step at a time.

If another command was sent while the instrument was in the process of ramping up the width, the command would be missed. Therefore, there must be a delay between commands to allow the instrument to process the command and to allow it to send any error messages back that may arise from the command.

In hardware handshaking mode, the PC must look at the CTS line before transmission of any data. If this signal is 0 (FALSE), then the instrument is busy and no data will be received. If this signal is 1 (TRUE), then the instrument is ready to receive data. Upon transmission of data, the PC must set the RTS line to 1 (TRUE). When the transmission is complete, this line should be returned to the 0 (FALSE) state.

In both modes, the BAUD rate must be set to 19200, parity set to none, data bits set to 8 and stop bits set to 1.

INSTRUMENT SYSTEM POWER UP

NORMAL POWER UP

When power is applied to UTEX pulser-receiver, the BIOS (contained in ROM) handles interrupts vectoring and operating system initializes the I/O peripherals on the microcontroller board.

Once the I/O space has been initialized, the instrument sends all of its current settings to the PC in the following format:

Data String	Description
MESUTEX Version 4.00 97/03/30[CR]	System version date and time
PV100[CR]	Pulse voltage = 200 V
PW5.00[CR]	Pulse width = 5.00 ns
PRF200[CR]	Pulse frequency = 200 Hz
RPC[CR]	
RG00[CR]	Pitch/Catch gain = 0 dB
RPE[CR]	
PEG-06[CR]	Pulse/Echo gain = -6 dB
RPE[CR]	Receiver mode = Pulse/Echo
TSI[CR]	Trigger source = internal
PON0[CR]	Pulser mode = off
SP1	System Power = on
SL0	Lock = off
RLA0	Relay A = off
RLB1	Relay B = on
IOA0	TTL I/O Line A = off
IOB0	TTL I/O Line B = off
IOC0	TTL I/O Line C = off
IOD0	TTL I/O Line D = off
FIN1	Filter output is normal
FLE0	Low Pass filter = off
LPF20	Low Pass Frequency = 20 MHz
FHE0	High Pass Filter = off
HPF1	High Pass Frequency = 1 MHz
LCA3064	LCA type = 3064

Once these messages have been sent out, the front panel power switch on the UT340 (the LED on the UT320) will begin to flash on and off in 1 second intervals.

INSTRUMENT SYSTEM POWER DOWN

The instrument will shut down if the back panel power switch is turned off, the power cord is removed or if a power failure occurs. The following describes how the instrument responds to a power loss.

When the power begins to fail, the CPU is interrupted from its current task and the system is shut down. All system variables are maintained in MRAM. When the power is restored, the settings that were present before the power failed are restored, with the exception of the operation of the pulser.

When power is restored, the voltage, width, and pulse frequency are restored, but the output is disabled. The Run Pulser button must be pressed to enable the output, or a PON1 command must be sent to the instrument.

INPUTS

ADDRESS (ADR)

This command is used to adjust the address of the instrument.

The address can be adjusted from 0 to 32. If the address entered is out of the range of 0 to 32, the message 'COMMAND MODIFIER OUT OF RANGE' will be sent to the PC. The current address is left unchanged and is reported back to the PC.

DESIGNATION (DSG)

This command is used to change the designation on an instrument to be either a Master or a Slave.

When set to be a master, communications to the instrument is via the RS-232 port. When set to a slave, communications is via the RS-485 port.

When disabled, the pulse voltage is turned off and the enabling circuitry on the UTPLS is disabled. The front panel power switch reverts to flashing in 1 second intervals.

DSG1 - sets the instrument to be a Master

DSG0 - sets the instrument to be a Slave

FILTER HIGH PASS ENABLE (FHE)

This command is used to turn the high pass filter on and off.

FHE1 - turns on the high pass filter

FHE0 - turns off the high pass filter

FILTER HIGH PASS FREQUENCY (HPF)

This command is used to adjust the cut-off frequency of the high pass filter.

The frequency can be adjusted from 1 MHz to 20 MHz in 1 MHz steps. If a frequency command is sent that is not a valid step size, this value will be rounded down to the closest valid value. The message

'INVALID COMMAND MODIFIER, VALUE ROUNDED DOWN' will be sent to the PC followed by the corrected HPF value. If the HPF entered is out of the range of 1 to 20 MHz, the message 'COMMAND MODIFIER OUT OF RANGE' will be sent to the PC. The current operating HPF is left unchanged and is reported back to the PC.

FILTER LOW PASS ENABLE (FLE)

This command is used to turn the low pass filter on and off.

FLE1 - turns on the low pass filter

FLE0 - turns off the low pass filter

FILTER LOW PASS FREQUENCY (LPF)

This command is used to adjust the cut-off frequency of the low pass filter.

The frequency can be adjusted from 20 MHz to 150 MHz in 1 MHz steps. If a frequency command is sent that is not a valid step size, this value will be rounded down to the closest valid value. The

message 'INVALID COMMAND MODIFIER, VALUE ROUNDED DOWN' will be sent to the PC followed by the corrected HPF value. If the LPF entered is out of the range of 20 to 150 MHz, the message 'COMMAND MODIFIER OUT OF RANGE' will be sent to the PC. The current operating LPF is left unchanged and is reported back to the PC.

FILTER OUTPUT PHASE (FIN)

This command is used to control whether the phase of the signal at the RF Output on the front panel is normal or inverted.

FIN1 - inverted RF output

FIN0 - normal RF output

FLOW CONTROL (FCE)

This command is used to enable or disable hardware handshaking on the RS-232 serial communications lines. If enabled, the Host communications software (PC) must look at the CTS line before transmission of any data. If this signal is 0 (FALSE), then the instrument is busy and no data will be received. If this signal is 1 (TRUE), then the instrument is ready to receive data. Upon transmission of data, the PC must set the RTS line to 1 (TRUE). When the transmission is complete, this line should be returned to the 0 (FALSE) state.

FCE1 - enables hardware handshaking

FCE0 - disables hardware handshaking

I/O LINE A CONTROL (IOA)

This command is used to change the voltage on I/O line A between 0 and +5 volts.

IOA1 - sets the voltage to be +5 volts

IOA0 - sets the voltage to be 0 volts

I/O LINE A DIRECTION (TAD)

This command is used to change the direction of I/O line A from an input to an output.

TAD1 - sets the line to be an output

TAD0 - sets the line to be an input

I/O LINE A FUNCTION (TAF)

This command is used to change the function of I/O line A from a toggle to a momentary.

TAF1 - sets the line to be a toggle push button

TAF0 - sets the line to be a momentary push button

I/O LINE A NAME (TAN)

This command is used to change the caption of I/O line A. After this command is sent, the instrument will send an {ACK}. Once this {ACK} is received, up to 9 characters can be sent to be the new caption. Characters after the ninth are ignored.

I/O LINE A POLARITY (TAP)

This command is used to change the polarity of I/O line A from an active high to active low.

TAP1 - sets the line to be active high

TAP0 - sets the line to be active low

I/O LINE A TRACKING (TAT)

This command is used to change the tracking of input A from automatic to request.

TAT1 - sets the tracking to be automatic

TAT0 - sets the tracking to be request

I/O LINE B CONTROL (IOB)

This command is used to change the voltage on I/O line B between 0 and +5 volts.

IOB1 - sets the voltage to be +5 volts

IOB0 - sets the voltage to be 0 volts

I/O LINE B DIRECTION (TBD)

This command is used to change the direction of I/O line B from an input to an output.

TBD1 - sets the line to be an output

TBD0 - sets the line to be an input

I/O LINE B FUNCTION (TBF)

This command is used to change the function of I/O line B from a toggle to a momentary.

TBF1 - sets the line to be a toggle push button

TBF0 - sets the line to be a momentary push button

I/O LINE B NAME (TBN)

This command is used to change the caption of I/O line B. After this command is sent, the instrument will send an {ACK}. Once this {ACK} is received, up to 9 characters can be sent to be the new caption. Characters after the ninth are ignored.

I/O LINE B POLARITY (TBP)

This command is used to change the polarity of I/O line B from an active high to active low.

TBP1 - sets the line to be active high

TBP0 - sets the line to be active low

I/O LINE B TRACKING (TBT)

This command is used to change the tracking of input B from automatic to request.

TBT1 - sets the tracking to be automatic

TBT0 - sets the tracking to be request

I/O LINE C CONTROL (IOC)

This command is used to change the voltage on I/O line C between 0 and +5 volts.

IOC1 - sets the voltage to be +5 volts

IOC0 - sets the voltage to be 0 volts

I/O LINE C DIRECTION (TCD)

This command is used to change the direction of I/O line C from an input to an output.

IOC1 - sets the line to be an output

IOC0 - sets the line to be input

I/O LINE C FUNCTION (TCF)

This command is used to change the function of I/O line C from a toggle to a momentary.

TCF1 - sets the line to be a toggle push button

TCF0 - sets the line to be a momentary push button

I/O LINE C NAME (TCN)

This command is used to change the caption of I/O line C. After this command is sent, the instrument will send an {ACK}. Once this {ACK} is received, up to 9 characters can be sent to be the new caption. Characters after the ninth are ignored.

I/O LINE C POLARITY (TCP)

This command is used to change the polarity of I/O line C from an active high to active low.

TCP1 - sets the line to be active high

TCPO - sets the line to be active low

I/O LINE C TRACKING (TCT)

This command is used to change the tracking of input C from automatic to request.

TCT1 - sets the tracking to be automatic

TCT0 - sets the tracking to be request

I/O LINE D CONTROL (IOD)

This command is used to change the voltage on I/O line D between 0 and +5 volts.

IOD1 - sets the voltage to be +5 volts

IOD0 - sets the voltage to be 0 volts

I/O LINE D DIRECTION (TDD)

This command is used to change the direction of I/O line D from an input to an output.

TDD1 - sets the line to be an output

TDD0 - sets the line to be an input

I/O LINE D FUNCTION (TDF)

This command is used to change the function of I/O line D from a toggle to a momentary.

TDF1 - sets the line to be a toggle push button

TDF0 - sets the line to be a momentary push button

I/O LINE D NAME (TDN)

This command is used to change the caption of I/O line D. After this command is sent, the instrument will send an {ACK}. Once this {ACK} is received, up to 9 characters can be sent to be the new caption. Characters after the ninth are ignored.

I/O LINE D POLARITY (TDP)

This command is used to change the polarity of I/O line D from an active high to active low.

TDP1 - sets the line to be active high

TDP0 - sets the line to be active low

I/O LINE D TRACKING (TDT)

This command is used to change the tracking of input D from automatic to request.

TDT1 - sets the tracking to be automatic

TDT0 - sets the tracking to be request

LCD CONTRAST CONTROL (CON)

This command is used to adjust the contrast of the front panel LCD.

The contrast may be adjusted from 0 to 127 in steps of 1. Any values that are outside of this range will be ignored.

CON100 - sets the LCD contrast to 100

LOCK (SL)

This command is used to lock the front panel controls and serial port adjustments so that the variables will not be accidentally adjusted.

SL1 - locks the instrument

SL0 - unlocks the instrument

OVER CURRENT RESET (OCR)

This command is used to reset the over current latch on the UTPLS module if the over current error shuts down the system.

OVER VOLTAGE RESET (OVR)

This command is used to reset the over voltage latch on the UTHVL module if the over voltage error shuts down the system.

PITCH CATCH GAIN (RPC)

This command is used to set the gain of the amplifiers to be used when the instrument is in Pitch Catch mode.

The gain can be adjusted in 1 dB steps from 0 to 63 dB. Only whole numbers are recognized; any decimal is invalid. If a gain command is sent that is not a valid step size, this value will be rounded down to the closest valid value. The message 'INVALID COMMAND MODIFIER, VALUE ROUNDED DOWN' will be sent to the PC followed by the corrected RPC value. If the RPC entered is out of the range, the message 'COMMAND MODIFIER OUT OF RANGE' will be sent to the PC. The current operating RPC is left unchanged and is reported back to the PC.

RPC - sets amplifiers to the desired gain (dB)

PULSE ECHO GAIN (PEG)

This command is used to set the gain of the amplifiers to be used when the instrument is in Pulse Echo mode.

The gain can be adjusted in 1 dB steps from -6 to 57 dB. Only whole numbers are recognized; any decimal is invalid. If a gain command is sent that is not a valid step size, this value will be rounded down to the closest valid value. The message 'INVALID COMMAND MODIFIER, VALUE ROUNDED DOWN' will be sent to the PC followed by the corrected PEG value. If the PEG entered is out of the range, the message 'COMMAND MODIFIER OUT OF RANGE' will be sent to the PC. The current operating PEG is left unchanged and is reported back to the PC.

PEG - sets amplifiers to the desired gain (dB)

PULSE REPETITION FREQUENCY (PRF)

This command is used to adjust the frequency of the internal pulse frequency generator.

The pulse frequency can be adjusted from 200 Hz to 20,000 Hz (20 kHz). Frequencies between 200 Hz and 1,000 Hz are adjustable in 100 Hz steps. Frequencies between 1,000 Hz and 20,000 Hz are adjustable in 1,000 Hz steps. If a frequency command is sent that is not a valid step size for the given range, this value will be rounded down to the closest valid value. The message 'INVALID COMMAND MODIFIER, VALUE ROUNDED DOWN' will be sent to the PC followed by the corrected PRF value. If the PRF entered is out of the range of 200 Hz to 20,000 Hz, the message 'COMMAND MODIFIER OUT OF RANGE' will be sent to the PC. The current operating PRF is left unchanged and is reported back to the PC.

PULSE VOLTAGE (PV)

This command is used to adjust the voltage of the pulse.

The pulse voltage can be adjusted from 100 to 500 V in 2 V steps (even voltages). If a voltage command is sent that is not a valid step size (an odd voltage or decimal increment), this value will be rounded down to the closest valid value. The message 'INVALID COMMAND MODIFIER, VALUE ROUNDED DOWN' will be sent to the PC followed by the corrected PV value. If the PV entered is out of the range of 100 to 500 V, the message 'COMMAND MODIFIER OUT OF RANGE' will be sent to the PC. The current operating PV is left unchanged and is reported back to the PC.

PULSE WIDTH (PW)

This command is used to adjust the width of the pulse.

The pulse width can be adjusted from 5 to 80 ns. From 5 to 45 ns the adjustments are in 0.50 ns steps, and from 45 to 80 ns the adjustments are in 0.20 ns steps. If a width command is sent that is not a valid step size for the given range, this value will be rounded down to the closest valid value. The message 'INVALID COMMAND MODIFIER, VALUE ROUNDED DOWN' will be sent to the PC followed by the corrected PW value. If the PW entered is out of the range of 5 to 80 ns, the message 'COMMAND MODIFIER OUT OF RANGE' will be sent to the PC. The current operating PW is left unchanged and is reported back to the PC.

PULSER RUN/STOP (PON)

This command is used to enable or disable the pulser.

When enabled, the pulser starts at its minimum settings and ramps up to the current settings. Width is ramped first, followed by voltage and then frequency. The front panel LED on the power switch will be on constantly.

When disabled, the pulse voltage is turned off and the enabling circuitry on the UTPLS is disabled. The front panel power switch reverts to flashing in 1 second intervals.

PON1 - enables the pulser

PON0 - disables the pulser

READ DATE AND TIME (RDT)

This command is used to request the system date and time. The data is returned in the following format: yy/mm/dd hh:mm:ss

RDT - request system date and time

RECEIVER GAIN (RG)

This command is used to set the gain of the amplifiers.

The gain can be adjusted in 1 dB steps from 0 to 63 dB in Pitch/Catch mode and -6 to 57 dB in Pulse/Echo mode. Only whole numbers are recognized; any decimal is invalid. If a gain command is sent that is not a valid step size, this value will be rounded down to the closest valid value. The

message 'INVALID COMMAND MODIFIER, VALUE ROUNDED DOWN' will be sent to the PC

followed by the corrected RG value. If the RG entered is out of the range for the current mode, the message 'COMMAND MODIFIER OUT OF RANGE' will be sent to the PC. The current operating RG is left unchanged and is reported back to the PC.

Note that the gain settings for each mode are independent.

RG - sets amplifiers to the desired gain (dB)

RECEIVER TO PITCH CATCH MODE (RPC)

This command is used to set the system to Pitch Catch mode. Upon receiving this command, the instrument will reset the gain of the amplifiers to the last setting for Pitch/Catch and send the current gain setting to the PC.

RPC - sets to Pitch Catch mode

RECEIVER TO PULSE ECHO MODE (RPE)

This command is used to set the system to Pulse Echo mode. Upon receiving this command, the instrument will reset the gain of the amplifiers to the last setting for Pulse/Echo and send the current gain setting to the PC.

RPE - sets to Pulse Echo mode

RELAY A CONTROL (RLA)

This command is used to open or close the Relay A contacts.

RLA1 - closes the contacts

RLA0 - opens the contacts

RELAY A FUNCTION (RAF)

This command is used to change the function of Relay A from a toggle to a momentary.

RAF1 - sets the line to be a toggle push button

RAF0 - sets the line to be a momentary push button

RELAY A NAME (RAN)

This command is used to change the caption of Relay A. After this command is sent, the instrument will send an {ACK}. Once this {ACK} is received, up to 9 characters can be sent to be the new caption. Characters after the ninth are ignored.

RELAY A POLARITY (RAP)

This command is used to change the polarity of Relay A from an active high to active low.

RAP1 - sets the line to be active high

RAP0 - sets the line to be active low

RELAY B CONTROL (RLB)

This command is used to open or close the Relay B contacts.

RLB1 - closes the contacts

RLB0 - opens the contacts

RELAY B FUNCTION (RBF)

This command is used to change the function of Relay B from a toggle to a momentary.

RBF1 - sets the line to be a toggle push button

RBF0 - sets the line to be a momentary push button

RELAY B NAME (RBN)

This command is used to change the caption of Relay B. After this command is sent, the instrument will send an {ACK}. Once this {ACK} is received, up to 9 characters can be sent to be the new caption. Characters after the ninth are ignored.

RELAY B POLARITY (RBP)

This command is used to change the polarity of Relay B from an active high to active low.

RBP1 - sets the line to be active high

RBP0 - sets the line to be active low

RETRANSMISSION STATUS (SRT)

This command is used to force the Master instrument not to transmit data to any of the Slaves.

SRT1 - stops the master from re-transmitting

SRT0 - allows the master to re-transmit

SYSTEM POWER ON/OFF (SP)

This command is used to turn the system power on and off.

SP1 - turns on the system power

SP0 - turns off the system power

SYSTEM SETTINGS (OK)

The "OK" command is used to request the current system settings from the instrument.

Upon reception of this command, the instrument will respond by sending out all of its settings as well as the current system firmware date. The data will come back in the following order:

Firmware Date
 Pulse voltage (PV)
 Pulse width (PW)
 Pulse Frequency (PRF)
 Pitch Catch Mode (RPC)
 Gain setting (RG)
 Pulse Echo Mode (RPE)
 Gain setting (RG)
 Current Pulse Mode (RPC or RPE)
 Trigger Source (TSI or TSE)
 Pulser Status (PON0 or PON1)
 System Power Status (SP1 or SP0)
 Lock Status (SLO or SL1)
 Relay A Status (RLA0 or RLA1)
 Relay B Status (RLB0 or RLB1)
 TTL Line A Status (IOA0 or IOA1)
 TTL Line B Status (IOB0 or IOB1)

TTL Line C Status (IOC0 or IOC1)
TTL Line D Status (IOD0 or IOD1)
Filter Output Phase (FIN0 or FIN1)
Low Pass Filter enable (FLE0 or FLE1)
Low Pass Frequency (LPF)
High Pass Filter enable (FHE0 or FHE1)
High Pass Frequency (HPF)
LCA Type (LCA)

SYSTEM TEMPERATURE (GST)

This command is used to request the current temperature inside the instrument.

Upon reception of this command, the instrument will respond by sending out the current temperature inside the instrument measured in Celsius.

TMP024.5

TRIGGER SOURCE (TSI/TSE)

This command is used to select if the instrument uses an internal trigger generator or an external source to trigger the pulser.

TSE - sets to use an external source
TSI - sets to use the internal generator

OUTPUTS

The following section describes the possible data that can be sent back to the PC from the UTEX pulser receiver. Any string that is prefixed by 'MES' should be treated as a message and displayed to the user. Message strings are terminated by a {CR}. Any other strings that are received should be treated as system adjustments.

If the instrument makes adjustments to the operating parameters, it will send commands back to the PC indicating what parameter was adjusted. The PC application must adjust its variables to match those of the instrument.

The following is a list of possible system adjustments:

PON

The instrument has changed the pulser status. Data will be displayed in the following format:

PON1{CR}

This would indicate that the pulser is running.

PON0{CR}

This would indicate that the pulser is off.

PRF

The instrument has changed the pulse repetition frequency. Data is displayed as follows:

PRF5000{CR}

This would indicate the frequency has been set to 5000 Hz.

PV

The instrument has changed the pulse voltage. Data is displayed as follows:

PV232{CR}

This would indicate the pulse voltage has been set to 232 V.

PW

The instrument has changed the pulse width. Data is displayed as follows:

PW55.00{CR}

This would indicate the pulse width has been set to 55.00 ns.

RG

The instrument has changed the amplifier gain for the current receiver mode. Data is displayed as follows:

RG55{CR}

This indicates the gain has been set to 55
dB.

PCG

The instrument has changed the amplifier gain for Pitch Catch mode. Data is displayed as follows:

PCG55{CR}

This indicates the gain has been set to 55
dB.

PEG

The instrument has changed the amplifier gain for Pulse Echo mode. Data is displayed as follows:

PEG55{CR}

This indicates the gain has been set to 55
dB.

RPC

The instrument has changed the receiver mode. Data is displayed as follows:

RPC{CR}

This indicates that the pulser is in Pitch/Catch
mode.

RPE

The instrument has changed the receiver mode. Data is displayed as follows:

RPE{CR}

This indicates that the pulser is in Pulse/Echo mode.

TSE

The instrument has changed the trigger source. Data is displayed as follows:

TSE{CR}

This indicates that the trigger source is now external.

TSI

The instrument has changed the trigger source. Data is displayed as follows:

TSI{CR}

This indicates that the trigger source is now internal.

RESPONSES TO QUERIES FROM THE PC

SYSTEM SETTINGS (OK)

In response to the 'OK' command from the PC, the instrument will send back data in the following format:

```

Firmware Date
Pulse voltage (PV)
Pulse width (PW)
Pulse Frequency (PRF)
Pitch Catch Mode (RPC)
Gain setting (RG)
Pulse Echo Mode (RPE)
Gain setting (RG)
Current Pulse Mode (RPC or RPE)
Trigger Source (TSI or TSE)
Pulser Status (PON0 or PON1)
System Power Status (SP1 or SP0)
Lock Status (SLO or SL1)
Relay A Status (RLA0 or RLA1)
Relay B Status (RLB0 or RLB1)
TTL Line A Status (IOA0 or IOA1)
TTL Line B Status (IOB0 or IOB1)
TTL Line C Status (IOC0 or IOC1)
TTL Line D Status (IOD0 or IOD1)
Filter Output Phase (FIN0 or FIN1)
Low Pass Filter enable (FLE0 or FLE1)
Low Pass Frequency (LPF)
High Pass Filter enable (FHE0 or FHE1)
High Pass Frequency (HPF)
LCA Type (LCA)

```

Example:

```

MESOS5.2F FPGA05 2016/11/25{CR}
PV100{CR}
PW5.00{CR} PRF200{CR}
RPC{CR}
RG00{CR}
RPC{CR}
RG00{CR}
PEG-06{CR}
TSI{CR}
PON0{CR}
SP1{CR}
SLO{CR}
RLA0{CR}
RLB1{CR}

```

IOA0{CR}
IOB0{CR}
IOC0{CR}
IOD0{CR}
FIN1{CR}
FLE0{CR}
LPF20{CR}
FHE0{CR}
HPF1{CR}

Note that each setting is separated by a carriage return{CR}.

ERRORS

The following is a description of the messages that the instrument will send to the PC when an error condition arises.

All of the following messages are prefixed by "MES" and are terminated by a {CR}.

COMMAND NOT SUPPORTED

This message is sent if the command sent from the PC is not supported.

DONE/PROGRAM LINE LOW AFTER LCA DATA SENT

The LCA has not programmed properly. When the instrument is in this state, the unit will not function as a pulser receiver. It is possible that the LCA data in the FLASH is corrupt. If this is the case, reprogramming the FLASH LCA data may resolve the problem. If this does not resolve the problem, it could indicate a low level hardware failure on the microcontroller board. In this case, call technical support at UTEX at (905)828-1313 or email us at tech-support@utex.com.

EXTERNAL PRF LIMITED

This message immediately follows the initial error message which stated the type of error that occurred. The instrument is resolving the problem by limiting the external trigger input to the maximum frequency that the system can safely handle given the present settings.

FLASH CORRUPTED

The FLASH has not been programmed. When the instrument is in this state, the unit will not function as a pulser receiver until the FLASH has been programmed. If you are unable to reprogram the FLASH, please call technical support at UTEX at (905)828-1313 or email us at tech-support@utex.com.

INTERNAL PRF LIMITED

This message immediately follows the initial error message which stated the type of error that occurred. The instrument is resolving the problem by rolling back the internal trigger pulse repetition frequency to the maximum frequency that the system can safely handle given the present settings.

INVALID INCREMENT, VALUE ROUNDED

This message is sent if the command sent from the PC is not a valid step size for the given variable to be adjusted.

INVALID SUPPLY NUMBER

This message is sent if the selected supply number within the 'PV' command does not exist.

MAX POWER LIMIT

This message is sent if the system is pulsing and the maximum power output has been achieved.

MAX POWER WHILE IDLE

This message is sent if the system is not pulsing and the maximum power output has been achieved. This could indicate that there is a possible catastrophic failure of the instrument high voltage power supply or one of its components. Turn the power to the instrument off, and then on again in an attempt to reset the system. In this case, call technical support at UTEX at (905)828-1313 or email us at tech-support@utex.com.

MAX POWER WHILE STARTING

On starting the pulser, the pulse voltage, pulse width and pulse frequency are set to the minimum values. The high voltage supply is enabled and the over-current and over-voltage circuits are reset. At this point, the pulser is enabled. If a maximum power signal occurs after a 10 ms delay, the system is shut down and this error is reported.

MAX POWER, HV ON

On starting the pulser, the pulse voltage, pulse width, and pulse frequency are set to the minimum values. Then the high voltage supply is enabled and the over-current and over-voltage circuits are reset. If a maximum power signal occurs, the system is shut down and this error is reported.

OVER-CURRENT

This message is sent if the system is pulsing and the over-current output has been triggered. The system is shut down and this error is reported. The front panel power switch will begin to flash in ¼ second intervals.

OVER-CURRENT WHILE IDLE

This message is sent if the system is not pulsing and the over-current output has been triggered. This could indicate that there is a possible catastrophic failure of the instrument pulser module or one of its components. The front panel power switch will begin to flash in ¼ second intervals. Turn the power to the instrument off, and then on again in an attempt to reset the system. In this case, call technical support at UTEX at (905)828-1313 or email us at tech-support@utex.com.

OVER-CURRENT, HV ON

On starting the pulser, the pulse voltage, pulse width, and pulse frequency are set to the minimum values. Then the high voltage supply is enabled and the over-current and over-voltage circuits are reset. If an over current signal occurs, the system is shut down and this error is reported. The front panel power switch will begin to flash in $\frac{1}{4}$ second intervals.

OVER-VOLTAGE

This message is sent if the system is pulsing and the over voltage output has been triggered. The system is shut down and this error is reported. The front panel power switch will begin to flash in $\frac{1}{2}$ second intervals.

OVER-VOLTAGE WHILE IDLE

This message is sent if the system is not pulsing and the over-voltage output has been triggered. This could indicate that there is a possible catastrophic failure of the instrument pulser module or one of its components. The front panel power switch will begin to flash in $\frac{1}{2}$ second intervals. Turn the power to the instrument off, and then on again in an attempt to reset the system. In this case, call technical support at UTEX at (905)828-1313 or email us at tech-support@utex.com.

OVER-VOLTAGE WHILE RUNNING

On starting the pulser, the pulse voltage, pulse width, and pulse frequency are set to the minimum values. Then the high voltage supply is enabled and the over-current and over-voltage circuits are reset. At this point, the pulser is enabled. If an over-voltage signal occurs after a 10 ms delay, the system is shut down and this error is reported. The front panel power switch LED will begin to flash in $\frac{1}{2}$ second intervals.

OVER-VOLTAGE WHILE STARTING

On starting the pulser, the pulse voltage, pulse width, and pulse frequency are set to the minimum values. The high voltage supply is enabled and the over-current and over-voltage circuits are reset. At this point, the pulser is enabled. If an over-current signal occurs, the system is shut down and this error is reported. The front panel power switch LED will begin to flash in $\frac{1}{4}$ second intervals.

OVER-VOLTAGE, HV ON

On starting the pulser, the pulse voltage, pulse width, and pulse frequency are set to the minimum values. Then the high voltage supply is enabled and the over-current and over-voltage circuits are reset. If an over-voltage signal occurs, the system is shut down and this error is reported. The front panel power switch will begin to flash in $\frac{1}{2}$ second intervals.

P/C GAIN CORRUPTED, SET TO MIN

This message is sent if, upon trying to restart the pulser, the previous setting for pitch/catch gain has been corrupted and is no longer within the proper operating limits. The system will correct this by setting the variable to its minimum setting.

P/E GAIN CORRUPTED, SET TO MIN

This message is sent if, upon trying to restart the pulser, the previous setting for pulse/echo gain has been corrupted and is no longer within the proper operating limits. The system will correct this by setting the variable to its minimum setting.

PRF CORRUPTED, SET TO MIN

This message is sent if, upon trying to restart the pulser, the previous setting for pulse repetition frequency has been corrupted and is no longer within the proper operating limits. The system will correct this by setting the variable to its minimum setting.

PULSE VOLTAGE LIMITED

This message immediately follows the initial error message which stated the type of error that occurred. The instrument is resolving the problem by rolling back the pulse voltage to the maximum voltage that the system can safely handle given the present settings.

PULSE WIDTH LIMITED

This message is sent after the initial error message stating the type of error that occurred. This is the systems resolution to the problem, meaning that the instrument has rolled back the pulse width to the maximum width that the system can handle given the present settings.

SETTINGS ARE MANUALLY LOCKED

This message is sent if any command is sent to adjust the instrument variables when the system has been locked using the SL1 command.

SYSTEM ERROR

This message is sent if there was a hardware failure of the system.

VALUE OUT OF RANGE

This message is sent if the command sent from the PC is out of range for the given variable to be adjusted.

VOLTAGE CORRUPTED, SET TO MIN

This message is sent if, upon trying to restart the pulser, the previous setting for pulse voltage has been corrupted and is no longer within the proper operating limits. The system will correct this by setting the variable to its minimum setting.

REAR PANEL CONNECTOR PIN ASSIGNMENTS

CONTROL INPUT/OUTPUT

Pin Number	Signal	Description
1	K1NO	Relay 1 normally open contact
2	K1NC	Relay 1 normally closed contact
3	K2COM	Relay 2 armature contact
4	USERIO4	Digital I/O line 4
5	USERIO2	Digital I/O line 2
6	ALARM+	System beeper + signal
7	GND	Signal ground
14	K1COM	Relay 1 armature contact
15	K2NO	Relay 2 normally open contact
16	K2NC	Relay 2 normally closed contact
17	USERIO3	Digital I/O line 3
18	USERIO1	Digital I/O line 1
19	ALARM-	System beeper - signal

RS-232

Pin Number	Signal	Description
2	RxD	Receive
3	TxD	Transmit
4	RTS	Request to send
5	CTS	Clear to send
7	GND	Signal Ground

RS-485

Pin Number	Signal	Description
2	RTS/CTS +	Positive differential handshake signal
4	RTS/CTS-	Negative differential handshake signal
5	TxD/RxD -	Negative differential data signal
7	TxD/RxD +	Positive differential data signal

WARRANTY

UTEX SCIENTIFIC INSTRUMENTS INC.

TWO YEAR LIMITED WARRANTY

Subject to each of the terms and conditions stated herein, UTEX SCIENTIFIC INSTRUMENTS INC. "UTEX" warrants to the original purchaser that should, in UTEX' judgement, the instrument prove defective by reason of improper workmanship and/or material, UTEX shall repair or replace, at its option, any defective part of the instrument without charge for the parts, for a period of two years from the date of the original purchase and shall, for such period, bear the entire labour expense for any warranty repair of the defective instrument or defective parts when such labor is performed at an authorized UTEX service center.

All parts used for replacement are warranted for the remainder of the original warranty period only. To obtain warranty service, the purchaser must notify an authorized UTEX service center of any alleged defect within the applicable warranty period.

1. **PROOF OF PURCHASE DATE IS REQUIRED WHEN REQUESTING WARRANTY SERVICE.** In order to obtain warranty service, the original purchaser must deliver the instrument to the nearest authorized UTEX service center. Shipping expenses are the purchaser's responsibility. The name and address of the nearest service center can be obtained from a UTEX dealer or by writing or calling UTEX at the address and telephone number provided. The original purchaser must present to the service center a sales receipt or other written evidence establishing proof and date of purchase of the instrument.
2. **THIS WARRANTY DOES NOT COVER** damage to the instrument caused by modification, alteration, physical abuse to, or misuse of, the instrument, by repair or service to the product by anyone other than an authorized UTEX service center; by operation in a manner contrary to the instructions which accompany the instrument; by freight damage; or by any other damage caused by circumstances beyond UTEX' control, such as lightning or fluctuation in electrical power. The purchaser is solely and totally responsible for installation and initial technical adjustments of the instrument; adjustment of user controls; and any required maintenance of the instrument. Please consult the operating instructions for information regarding user controls.
3. Any express warranty not provided herein, and any remedy which, but for this provision, might arise by implication or operation of law is hereby excluded and disclaimed. The implied warranties of merchantability and of fitness for any particular purpose are expressly limited to a term of two years.
4. Under no circumstances shall UTEX be liable to the original purchaser or any other person for any incidental, special or consequential damages, whether arising out of breach of warranty, breach of contract, or otherwise.
5. For the name of the nearest authorized UTEX service center, call 905-828-1313 or e-mail to tech-support@utex.com.
6. **Do not send your instrument** without first contacting UTEX Scientific Instruments Inc. for your return materials authorization number (RMA).

Please take a minute to complete the Warranty Registration Form on the following page.

PRODUCT AND WARRANTY REGISTRATION

Thank you for purchasing a UTEX Scientific instrument. In order to allow us to serve you better, we ask that you please complete and return the following registration form by mail or fax to:

<p>UTEX Scientific Instruments Inc. 2319 Dunwin Drive, Unit 8 Mississauga, Ontario L5L 1A3 Tel: 905-828-1313 Fax: 905-828-0360 E-mail: tech-support@utex.com</p>
--

PRODUCT:	_____	SERIAL NUMBER:	_____
ORGANIZATION:	_____	CONTACT:	_____
ADDRESS:	_____	TEL:	_____
	_____	FAX:	_____
	_____	E-MAIL:	_____
	_____		_____

PURCHASE DATE: _____ PURCHASED FROM: _____
 (Please include proof of purchase with registration form.)

APPLICATION: _____

PLEASE LIST ANY OTHER HARDWARE OR SOFTWARE YOU ARE USING WITH THIS EQUIPMENT:

SIGNATURE: _____ DATE: _____